



03651-0379

**easy-click
system**



F-4E PHANTOM II

Beiliegenden Sicherheitstext beachten / Please note the enclosed safety advice

- Ⓔ Beiliegenden Sicherheitstext beachten und nachschlagbereit halten.
- ⒸⒺ Please note the enclosed safety advice and keep safe for later reference.
- ⒻⒺ Respecter les consignes de sécurité ci-jointes et les conserver à portée de main.
- ⒼⒺ Houdt u aan de bijgaande veiligheidsinstructies en hou deze steeds bij de hand.
- ⒿⒺ Seguire le avvertenze di sicurezza allegate e tenerle a portata di mano.
- ⒺⒺ Observar y siempre tener a disposición este texto de seguridad adjunto.
- ⓅⒺ Ter em atenção o texto de segurança anexo e guardá-lo para consulta.
- ⓃⒺ Overhold vedlagte sikkerhedsanvisninger og hav dem liggende i nærheden.
- ⓃⒺ Na alltid vedlagt sikkerhetstekst klar til bruk.
- ⒺⒺ Beakta bifogad säkerhetstext och håll den i beredskap.
- ⒻⒺ Huomioi ja säilytä oheiset varoitukset.
- ⒺⒺ Соблюдать технику безопасности, сохранить инструкцию для дальнейших обращений.
- ⒻⒺ Przestrzegać załączonego tekstu dotyczącego bezpieczeństwa i mieć go zawsze pod ręką.
- ⒺⒺ Dodržujte tento příložený bezpečnostní text a mějte ho po ruce.
- ⒻⒺ A mellékelt biztonsági szöveget vegye figyelembe és tartsa fellepozásra készen.
- ⒺⒺ Respektujte příložený bezpečnostní text a uchovávejte ho pro budouce použití.
- ⒺⒺ Respectați textul de siguranță atașat și păstrați-l la îndemână.
- ⒺⒺ Спазвайте приложениа текст за безопасност и го дръжте под ръка за справки.
- ⒺⒺ Priložena varnostna navodila izvajajte in jih hranite na vsem dostopnem mestu.
- ⒺⒺ Λάβετε υπόψη σας το συννημένο κείμενο ασφαλείας και φυλάξτε το ώστε να ανατρέχετε σε αυτό όποτε χρειάζεται.
- ⒻⒺ Ektekiqüvenlik talimatlarını dikkate alıp, bakabileceğiniz bir şekilde muafaza ediniz.

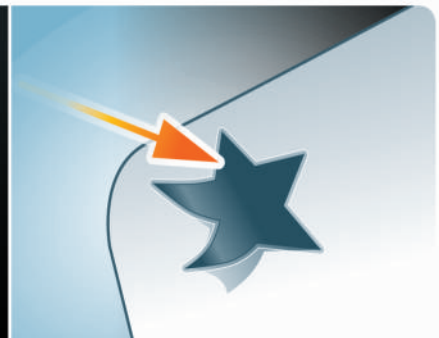
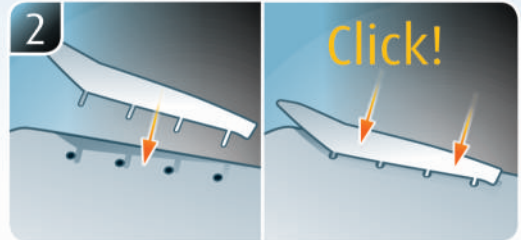
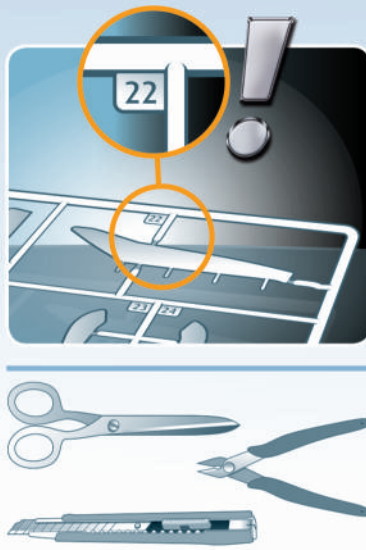

Painting



Decals

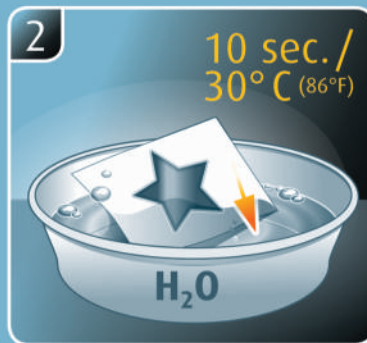
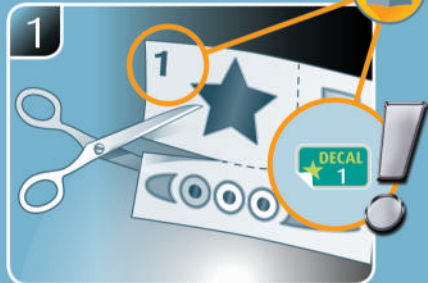

OPTIONAL · OPTIONAL · EN OPTION
OPTIONEEL · OPCIONAL · OPTIONAL *



(DE) Weitere Tipps und Tricks.
 (EN) Additional tips and tricks.
 (FR) Conseils et astuces supplémentaires.
 (NL) Andere tips en trucs.
 (IT) Ulteriori consigli e suggerimenti.
 (ES) Consejos y sugerencias adicionales.
 (PT) Mais dicas e truques.
 (FI) Flere tips og tricks.
 (NO) Flere tips og tricks.
 (SE) Ytterligare tips och tricks.
 (F) Lisää vinkkejä ja nikkejä.
 (RU) Другие советы и хитрости.

(PL) Dalsze wskazówki i sugestie.
 (CZ) Další tipy a rady.
 (HU) További ötletek és fogások.
 (SK) Ďalšie tipy a triky.
 (RO) Alte sfaturi și trucuri.
 (BG) Други полезни съвети и трикове.
 (SI) Nadaljnji nasveti in zvižace.
 (GR) Πρόσθετες συμβουλές και κόλπα.
 (TR) Diğer öneriler ve ipuçları.

www.revell.de

* (PT) Opcional
 (DK) Valgfrit
 (NO) Valgfritt
 (SE) Övrigt
 (FI) Valinnainen
 (RU) Дополнительно
 (PL) Opcja
 (CZ) Volitelný krok

(HU) Opcióként
 (SK) Voliteľné
 (RO) Opțional
 (BG) Опция
 (SI) Dodatno
 (GR) Προαιρετικά
 (TR) Opsiyonel



DE Bemalen
EN Paint
FR Peindre
NL Beschilderen
IT Colorare
ES Pintar
PT Pintar
HU Mal
NO Male
SE Måla
FI Maalaa
RU Раскрасить
PL Pomalować
CZ Pomalovat
HU Fesse be
SK Natrief
NO Vopsiitj
BG Боядисайте
SI Pobavajte
HR Бојацте
TR Boyama

2X

DE Anzahl der Arbeitsgänge.
EN Number of working steps.
FR Nombre d'étapes de travail.
NL Het aantal bouwstappen.
IT Numero di fasi di lavoro.
ES Número de pasos de trabajo.
PT Número de passos de trabalho.
HU Antal arbedjsgange.
NO Antall arbeidstrinn.
SE Antal operationer.
FI Työvaiheiden määrä.
RU Количество операций.
PL Liczba cykli roboczych.
CZ Počet pracovních kroků.
HU A munkamenetek száma.
SK Počet pracovných operácií.
NO Numärlu etapelor de lucru.
BG Брой работни стъпки.
SI Število delovnih postopkov.
HR Аριθμός βημάτων εργασιών.
TR Çalışma adımı sayısı.

1.

DE Zusammenbau Reihenfolge.
EN Sequence of assembly.
FR Ordre d'assemblage.
NL Volgorde van montage.
IT Sequenza di assemblaggio.
ES Secuencia de montaje.
PT Sequência de montagem.
HU Samlerækkefølge.
NO Monteringsrekkefølge.
SE Montering ordningsföljd.
FI Kokoamisjärjestys.
RU Последовательность сборки.
PL Kolejność montażu.
CZ Pořadí složení.
HU Összerakási sorrend.
SK Poradie zostavenia.
NO Ordinea asamblării.
BG Последовательност наглобяване.
SI Vrstni red sestavljanja.
HR Сειρά τοποθέτησης.
TR Parçaları birleştirme sırası.



DE Achtung
EN Attention
FR Attention
NL Obgelet
IT Attenzione
ES Atención
PT Atenção
HU Obs!
NO OBS
SE OBS
FI Huomio
RU Внимание
PL Uwaga
CZ Pozor
HU Figyelem!
SK Pozor
NO Atentje
BG Внимание
SI Pozor
HR Προσοχή
TR Dikkat



DE Klarsichtteile
EN Clear parts
FR Pièces transparentes
NL Transparente onderdelen
IT Parti trasparenti
ES Piezas transparentes
PT Peças transparentes
HU Klare dele
NO Klare deler
SE Genomsiktliga detaljer
FI Läpinäkyvät osat
RU Прозрачные детали
PL Przejrzyste części
CZ Průhledné díly
HU Átlátszó alkatrészek
SK Číre diely
NO Piese transparente
BG Прозрачни части
SI Prozorni deli
HR Διαφανή μέρη
TR Şeffaf parçalar



DE Abbildung zusammengesetzter Teile.
EN Illustration of assembled parts.
FR Figure représentant les pièces assemblées.
NL Afbeelding van samengevoegde onderdelen.
IT Foto delle parti assemblate.
ES Figura de las piezas montadas.
PT Ilustração das peças montadas.
HU Illustration af samlede dele.
NO Figur av sammensatte deler.
SE Bild på sammansatta detaljer.
FI Koottujen osien kuva.
RU Изображение смонтированных деталей.
PL Rysunek połączonych części.
CZ Zobrazení spojených dílů.
HU Összerakott alkatrészek ábrája.
SK Obrázok dielov, ktoré sa majú zmontovať.
NO Figura representând piesele asamblate.
BG Изображение наглобениите части.
SI Slika sestavljenih delov.
HR Απεικόνιση των τοποθετημένων μερών.
TR Birleştirilmiş parçalar resmi.



DE Abziehbild in Wasser einweichen und anbringen.
EN Soak and apply decals.
FR Mouiller et appliquer les décalcomanies.
NL Transfer in water even laten weken en aanbrengen.
IT Immergere la decalcomania nell'acqua e applicarla.
ES Mojar y aplicar calcomanías.
PT Amolecer o decalque em água e aplicar.
HU Gør overføringsbilledet vådt og sæt det på.
NO Myk opp avtrekingsbildet i vann og sett det på.
SE Blötlägg dekalen i vatten och sätt på den.
FI Pehmitä siirtokuva vedessä ja siirrä paikalleen.
RU Опустите переводную картинку в воду и нанесите её.
PL Namoczyć kalkomanię w wodzie i przykleić.
CZ Nechte obtisk odmočit ve vodě a přilepte.
HU Merítse vízbe és helyezze fel a matricát.
SK Obtlačkový obrázok namočte do vody a priložte na plochu.
NO Innmøtati abtbildul in apă și aplicați-l.
BG Потопете ваденката във вода и я поставете.
SI Prelepnicu namakajte v vodi. In namestite.
HR Моквакните се веро и топоветите те хаљкоманије.
TR Çikartmayı suda yumuşatın ve takın.



DE Zur Anbringung der Abziehbilder empfohlen.
EN Recommended for affixing the decals.
FR Recommandé pour l'application des décalcomanies.
NL Aanbevolen voor het aanbrengen van de transfers.
IT Raccomandato per l'applicazione delle decalcomanie.
ES Recomendado para fijar bien las calcomanías.
PT Recomendado para a fixação dos autocolantes.
HU Anbefales til anbringelse af overføringsbillederne.
NO Anbefales til å feste avtrekksbilder.
SE Rekommenderad för montering av klisterdekalerna.
FI Suositellaan siirtokuvien siirtämiseen.
RU Рекомендуется для нанесения переводных картинок.
PL Zalecane do przyklejenia kalkomani.
CZ Doporučujeme k umístění obtiskovacích obrázků.
HU A matrica felhelyezéséhez ajánlható.
SK Odporúča sa pre umiestnenie obtlačkového obrázku.
NO Recomandat pentru aplicarea abtbildurilor.
BG Препоръчва се за поставяне на ваденки.
SI Pri nameščanju nalepnic uporabite.
HR Συνιστάται για την τοποθέτηση των χαλκομανιών.
TR Çikartmaların takılması için önerilir.



DE Nicht enthalten
EN Not included
FR Non fourni
NL Behoort niet tot de levering
IT Non incluso
ES No incluido
PT Não incluído
HU Medfølger ikke
NO Ikke inkludert
SE Ingår ej
FI Ei sisällä
RU Не содержится
PL Nie wchodzi w zakres dostawy
CZ Není obsaženo
HU Nem tartalmazza
SK Neobsahuje
NO Nu este inclus
BG Не се включва в комплекта
SI Ni priloženo
HR Δεν περιλαμβάνεται
TR İçerilmiyor

OPTIONAL · OPTIONAL · EN OPTION · OPTIONEEL · OPCIONAL · OPTIONAL *

☞ Optional kann das Modell zusätzlich bemalt werden und wird damit zum ganz persönlichen Unikat. Wir empfehlen folgende Revell-Farben:

☞ The model can also be painted, which makes it completely unique. We recommend the following Revell paints:

☞ En option, il est aussi possible de peindre le modèle. Il devient alors une pièce vraiment unique et personnalisée. Nous vous recommandons les couleurs Revell suivantes :

☞ Optoneel kan het model aanvullend worden beschilderd om het een heel persoonlijke, unieke uitstraling te geven. Wij bevelen de volgende verf van Revell aan:

☞ Opcionalmente, el modelo se puede pintar para convertirlo en una pieza única personalizada. Recomendamos las siguientes pinturas de Revell:

☞ In via opzionale il modellino può essere verniciato per ottenere un esemplare del tutto personalizzato. Consigliamo di utilizzare i seguenti colori Revell:

☞ Opcionalmente, o modelo pode ser ainda pintado, dando-lhe um caráter pessoal único. Recomendamos as seguintes tintas Revell:

☞ Du kan vælge også at male modellen, som på den måde bliver personlig og unik. Vi anbefaler følgende Revell-farver:

☞ Du har mulighed til å gjøre modellen helt unik ved å male den. Vi anbefaler følgende Revell-farger:

☞ Modellen kan även målas och därmed bli en helt unik Unikat. Vi rekommenderar följande Revell-färger:

☞ Jos haluat yksilöllisen lopputuloksen, voit halutessasi myös maalata mallin. Suosittelemme käyttämään seuraavia Revell-maaleja:

☞ В качестве дополнения модель может быть окрашена, что придаст ей персональные, уникальные черты. Мы рекомендуем следующие цвета Revell:

☞ Opcjonalnie można dodatkowo pomalować model, który dzięki temu będzie całkowicie osobistym unikatem. Polecamy następujące farby Revell:

☞ Model se může dodatečně pomalovat, čímž vznikne zcela jedinečný originál. Doporučujeme použít barvy značky Revell:

☞ Opcióként a modell kiegészítő festéssel is ellátható, így igazán egyedivé tehető. Ehhez a következő Revell festékeket ajánljuk:

☞ Model sa môže dodatočne pomalovať, čím vznikne celkom jedinečný originál. Odporúčame použiť tieto farby značky Revell:

☞ Opțional, pentru un aspect unic, personalizat, pe model se poate aplica un strat suplimentar de vopsea. Vă recomandăm următoarele vopsele Revell:

☞ Опционално моделът може допълнително да бъде изпълнен в друг цвят и да се превърне в абсолютен уникат. Препоръчваме следните цветове на Revell:

☞ Po želji je moguće model dodatno prebarvati in ga tako spremeniti v osebni unikat. Priporočamo naslednje barve Revell:

☞ Προαιρετικά μπορεί το μοντέλο να βαφεί και να γίνει ένα τελείως προσωπικό μοναδικό κομμάτι. Συνιστούμε τα παρακάτω χρώματα Revell:

☞ Opsiyonel olarak model boyanabilir ve benzersiz hale getirilebilir. Şu Revell renklerini tavsiye ediyoruz:

05

A

- ☞ Weiß matt
- ☞ White matt
- ☞ Blanc mat
- ☞ Wit mat
- ☞ Bianco opaco
- ☞ Blanco mate
- ☞ Branco mate
- ☞ Hvid mat
- ☞ Hvit matt
- ☞ Vit matt
- ☞ Valkoinen matta
- ☞ Белый матовый
- ☞ Biały matowy
- ☞ Bílá matný
- ☞ Fehér, fénytelen
- ☞ Biela matný
- ☞ Alb mat
- ☞ Бяло матово
- ☞ Bela mat
- ☞ Ασπρο ματ
- ☞ Beyaz mat

09

B

- ☞ Anthrazit matt
- ☞ Anthracite matt
- ☞ Anthracite mat
- ☞ Antraciet mat
- ☞ Antracite opaco
- ☞ Antracita mate
- ☞ Antracite mate
- ☞ Antracitgrå mat
- ☞ Antrasitt matt
- ☞ Antracitgrå matt
- ☞ Antrasiitinharmaa matta
- ☞ Антрацит матовый
- ☞ Antracyt matowy
- ☞ Antracitová šedá matný
- ☞ Antracit, fénytelen
- ☞ Čierna uhlová matný
- ☞ Antracit mat
- ☞ Антрацит матово
- ☞ Antracit mat
- ☞ Γκρι ανθρακί ματ
- ☞ Antrazit mat

91

C

- ☞ Eisen metallic
- ☞ Iron metallic
- ☞ Fer métallique
- ☞ Ijzer metallic
- ☞ Ferro metallico
- ☞ Acero metálico
- ☞ Aço metálico
- ☞ Stål metallisk
- ☞ Jern metallic
- ☞ Stål metallic
- ☞ Teräs metallinen
- ☞ Сталь металлик
- ☞ Grafit metaliczny
- ☞ Ocelová metalizovaný
- ☞ Acélmetál
- ☞ Ocelová metaliza
- ☞ Fier metallic
- ☞ Железо металик
- ☞ Żelazna kovinska
- ☞ Χρώμα σιδήρου μεταλλικό
- ☞ Metalik metalik

39

D

- ☞ Dunkelgrün matt
- ☞ Dark green matt
- ☞ Vert foncé mat
- ☞ Donkergroen mat
- ☞ Verde scuro opaco
- ☞ Verde oscuro mate
- ☞ Verde escuro mate
- ☞ Mørkegrøn mat
- ☞ Mørk grønn matt
- ☞ Mörkgrön matt
- ☞ Tummanvihreä matta
- ☞ Темно-зелёный матовый
- ☞ Ciemnozielony matowy
- ☞ Tmavá zelená matný
- ☞ Sötétzöld, fénytelen
- ☞ Tmavo zelená matný
- ☞ Verde-inchis mat
- ☞ Тьмнозелено матово
- ☞ Temno-zelena mat
- ☞ Πράσινο σκούρο ματ
- ☞ Koyu yeşil mat

76

E

- ☞ Hellgrau matt
- ☞ Light grey matt
- ☞ Gris clair mat
- ☞ Lichtgrijs mat
- ☞ Grigio chiaro opaco
- ☞ Gris claro mate
- ☞ Cinza claro mate
- ☞ Lysegrå mat
- ☞ Lysegrå matt
- ☞ Ljusgrå matt
- ☞ Vaaleanharmaa matta
- ☞ Светло-серый матовый
- ☞ Jasnoszary matowy
- ☞ Světlá šedivá matný
- ☞ Világosszürke, fénytelen
- ☞ Svetlo sivá matný
- ☞ Gri-deschis mat
- ☞ Светлосиво матово
- ☞ Svetlo-siva mat
- ☞ Γκρι ανοιχτό ματ
- ☞ Açık gri mat

* ☞ Opcional
☞ Valgfritt
☞ Valgfritt

☞ Övrigt
☞ Valinnainen
☞ Дополнительно

☞ Opcja
☞ Voliteľný krok
☞ Opcióként

☞ Voliteľné
☞ Opțională
☞ Опция

☞ Dodatno
☞ Προαιρετικά
☞ Opsiyonel

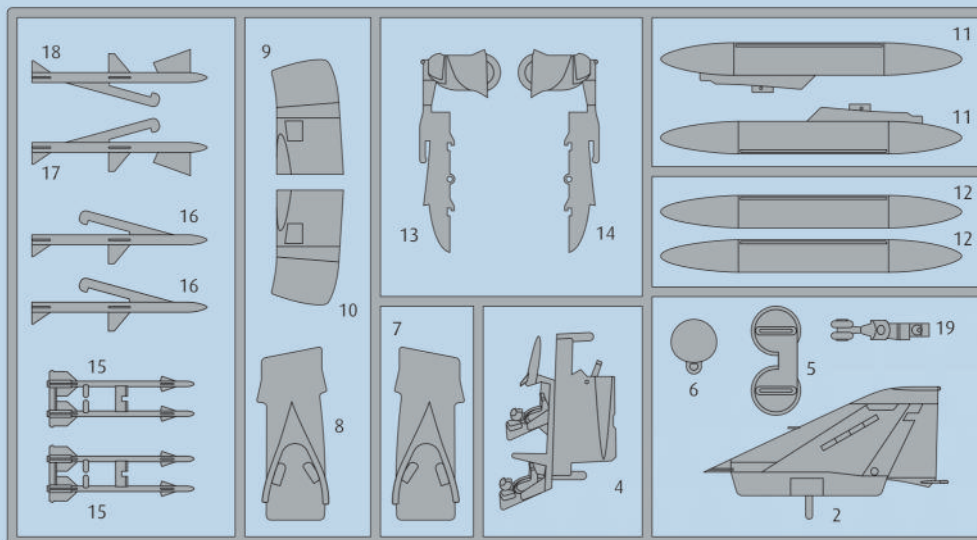
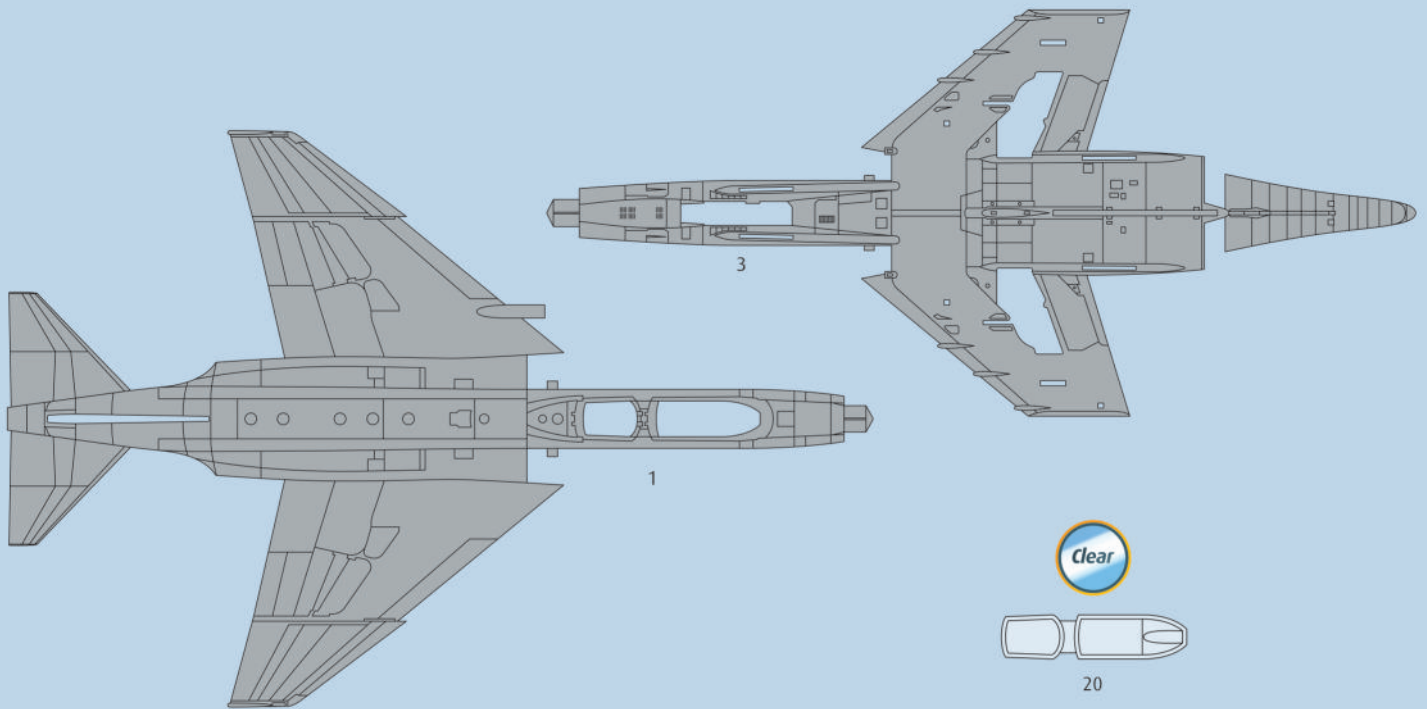

Ersatzteile benötigt?

Kein Problem. Einfach den Revell-Service mit Angabe von Artikel- und Teilenummer kontaktieren. Entweder unter service@revell.de oder Revell GmbH, Abteilung X, Henschelstr. 20-30, 32257 Bünde.*

*Wir bitten um Verständnis, dass eine Gewährleistung nur bei aktuellen Artikeln, die im Zeitraum der letzten 24 Monate erworben wurden, übernommen werden kann. Mit der Ersatzteil-Bestellung können Kosten z.B. für Verpackung und Versand entstehen. Ob diese Kosten anfallen wird im Vorfeld schriftlich durch unseren Service mitgeteilt. Das Angebot kann dann angenommen oder abgelehnt werden. Unfrei eingesandte Ersatzteil-Bestellungen werden von uns nicht angenommen! Dieser Direktservice gilt für die Länder Deutschland, Benelux, Österreich, Frankreich, Großbritannien. Ersatzteil-Bestellungen aus den übrigen Ländern werden über die jeweiligen Distributeure abgewickelt. Bitte kontaktieren Sie Ihren Händler.

Besoin de pièces de rechange ?

Il vous suffit de contacter le service Revell et d'indiquer la référence de l'article et de la pièce. Soit en écrivant par mail à france@revell.de (uniquement pour la France) ou par courrier à Revell GmbH, Département X, Henschelstr. 20-30, D-32257 Bünde.*

*La garantie s'applique pour les articles présents au catalogue et achetés au cours des 24 derniers mois. Merci de votre compréhension. La commande de pièces de rechange peut donner lieu à des frais supplémentaires, par ex. pour l'emballage et le port. Notre service client vous en informera au préalable par écrit. Vous pourrez accepter ou refuser le devis. Nous n'acceptons pas les commandes de pièces de rechange envoyées sans affranchissement ! Ce service direct est valable pour les pays suivants : Allemagne, Benelux, Autriche, France, Grande-Bretagne. Les commandes de pièces en provenance d'autres pays sont traitées par les distributeurs correspondants. Veuillez contacter votre revendeur.

Need spare parts?

No problem. Contact Revell Service with the item number and part numbers you need: service@revell.de or Revell GmbH, Unit 10, Old Airfield Industrial Estate, Cheddington Lane, Tring, Herts, HP23 4QR, Great Britain.*

*We request your understanding that a warranty can only be accepted for current articles which have been purchased in the last 24 months. Orders for spare parts may also be subject to costs for packaging and shipping. You will be notified in advance by our Service department if such costs are incurred. The offer can then be accepted or rejected. We will not be able to process any postal requests unless correct postage has been applied to mailing! This direct service applies to the countries: Germany, Benelux, Austria, France, and the United Kingdom. Spare part orders from other countries are processed by the local distributors. Please contact your dealer.

Hebt u reserveonderdelen nodig?

Geen probleem! Neem eenvoudig contact op met de klantenservice van Revell en geef ons het artikel- en onderdeelnummer door. U kunt ons bereiken op service@revell.de of per post: Revell GmbH, Afdeling X, Henschelstr. 20-30, 32257 Bünde.*

*Wij vragen uw begrip voor de omstandigheid, dat er alleen garantie kan worden geboden voor actuele artikelen, die in de afgelopen 24 maanden zijn gekocht. Met het bestellen van reserveonderdelen kunnen kosten gemoeid zijn, bijv. voor verpakking en verzending. U wordt vooraf schriftelijk door onze klantenservice op de hoogte gesteld als er kosten zouden ontstaan. Het aanbod kan dan worden aangenomen of afgewezen. Wij nemen geen ongefrankeerde bestellingen van reserveonderdelen aan! Deze rechtstreekse service wordt verleend in de landen Duitsland, de Benelux, Oostenrijk, Frankrijk en Groot-Brittannië. Bestellingen van reserveonderdelen in de overige landen worden afgewikkeld via de betreffende distributeurs. Neem hiervoor contact op met uw verkoper.

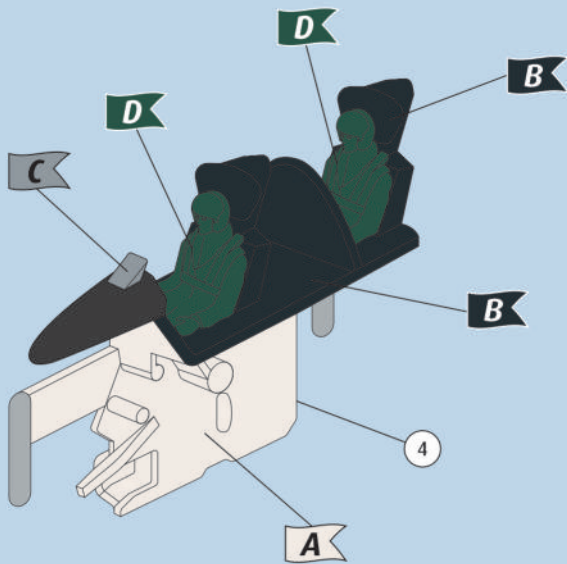
1 

2

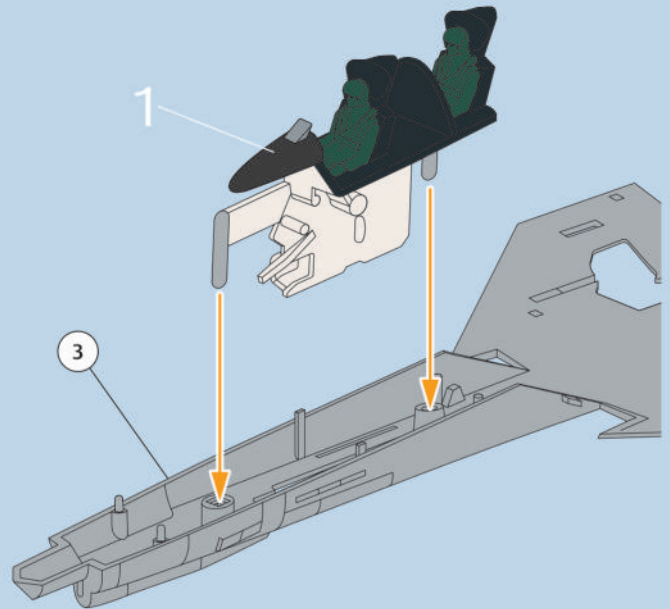
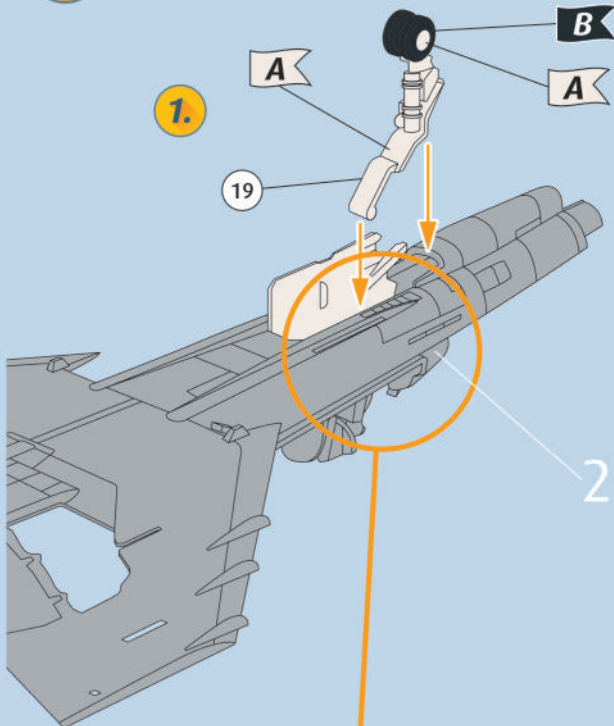
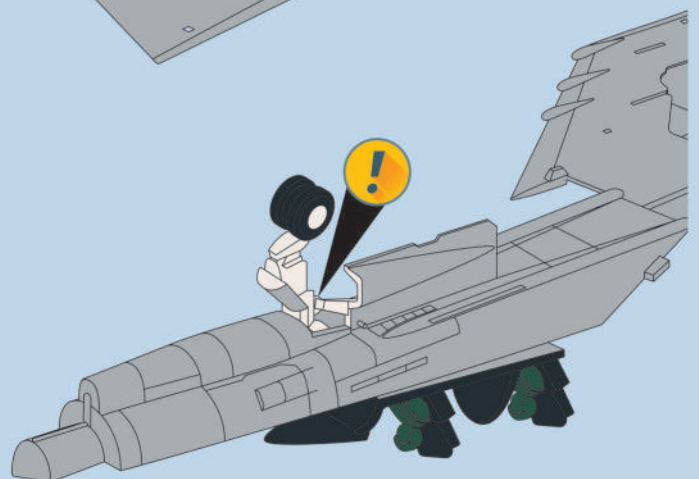
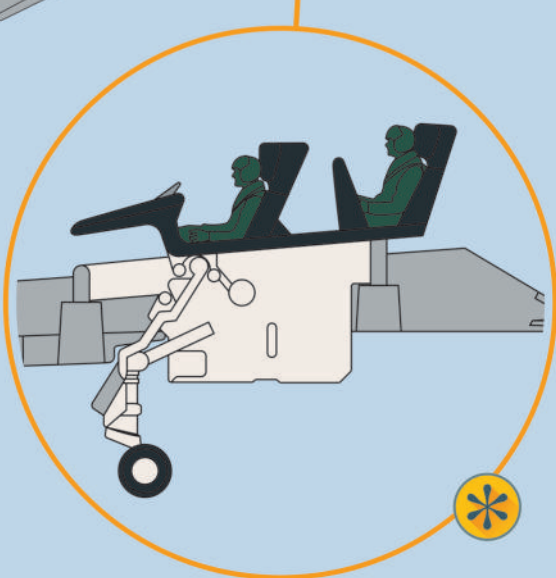
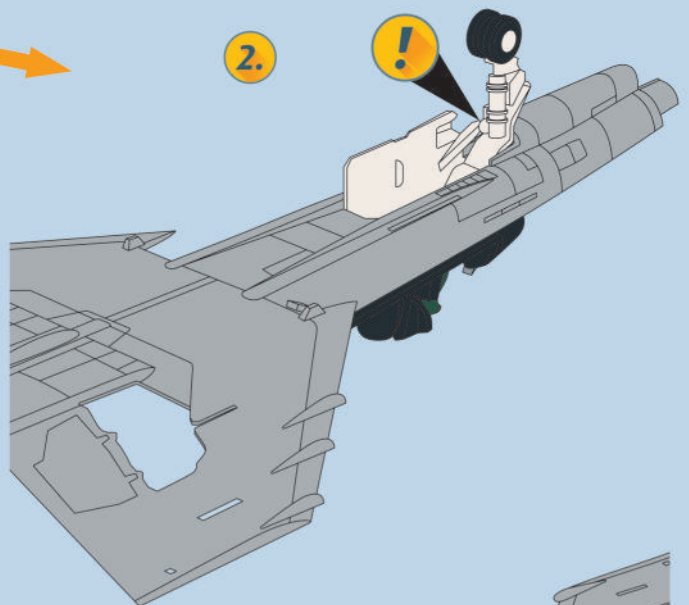
3 2. 

4 

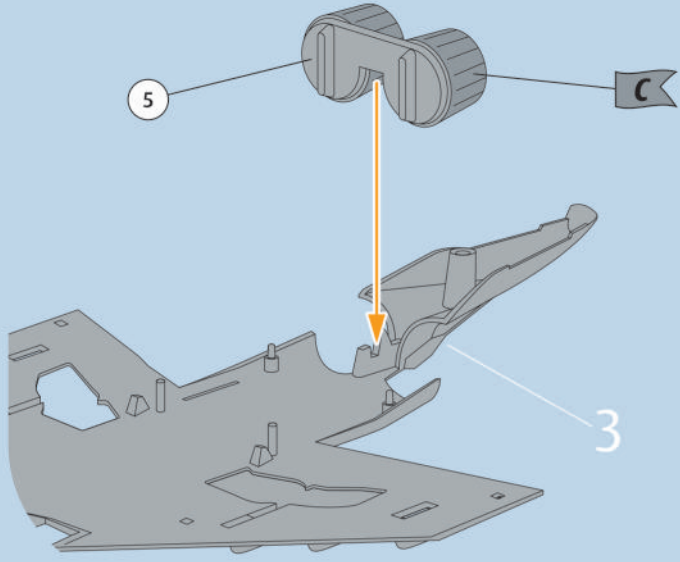

5 

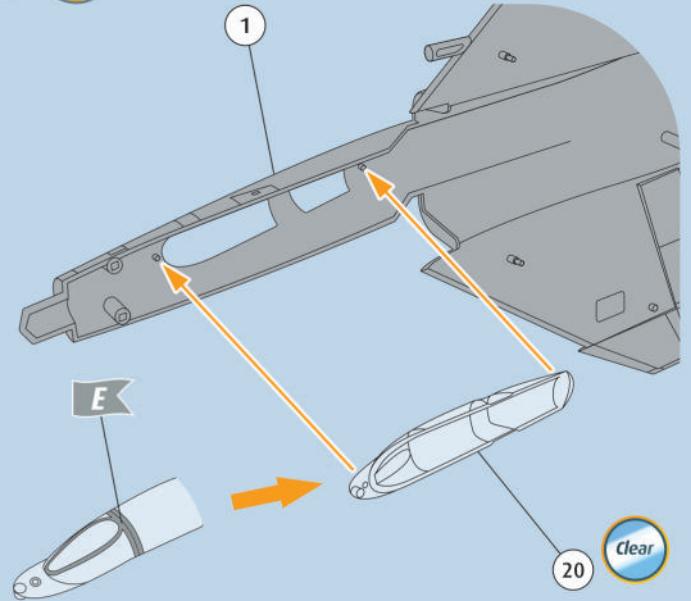

6 

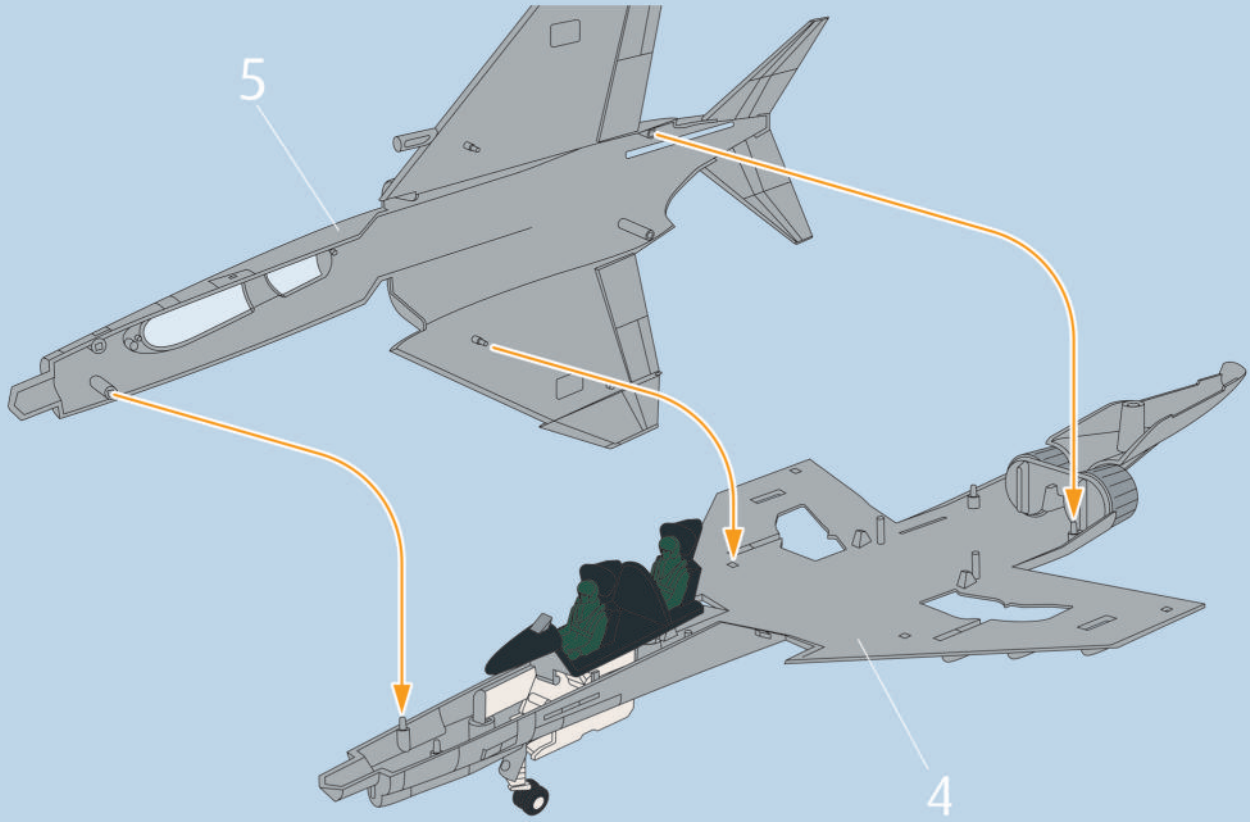

7

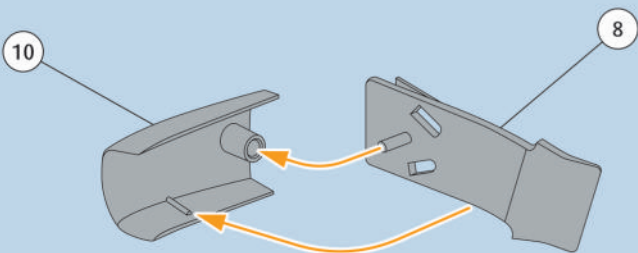

8

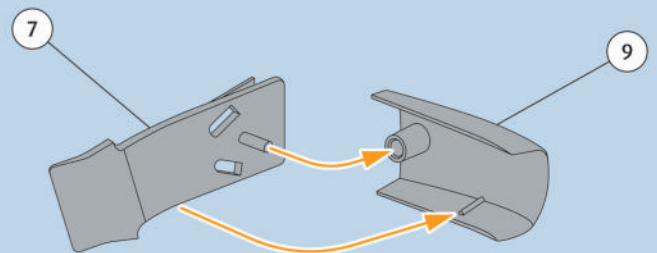

9

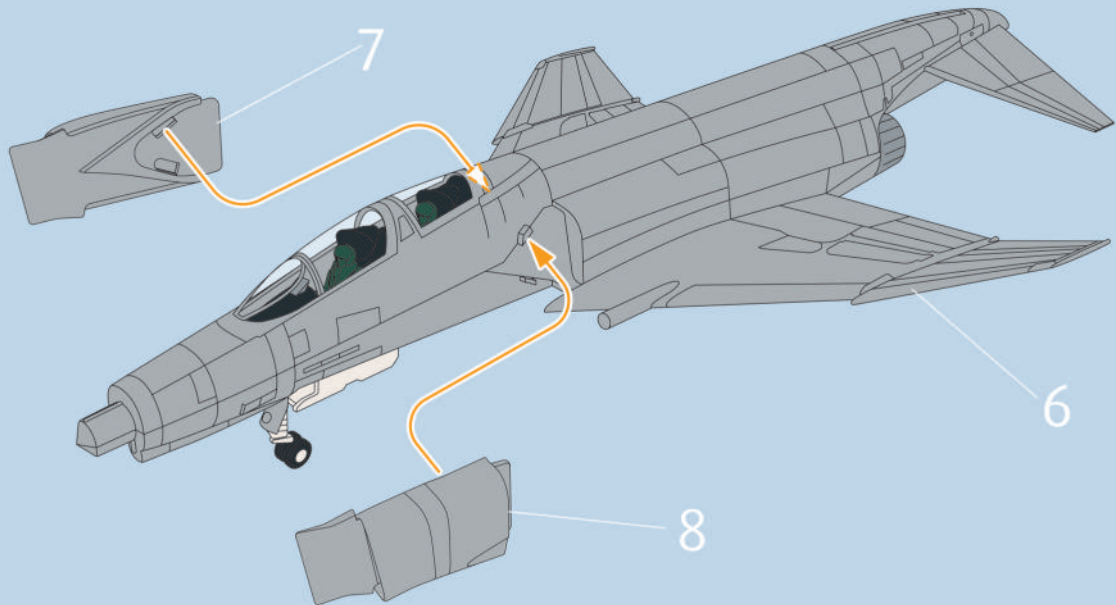

10

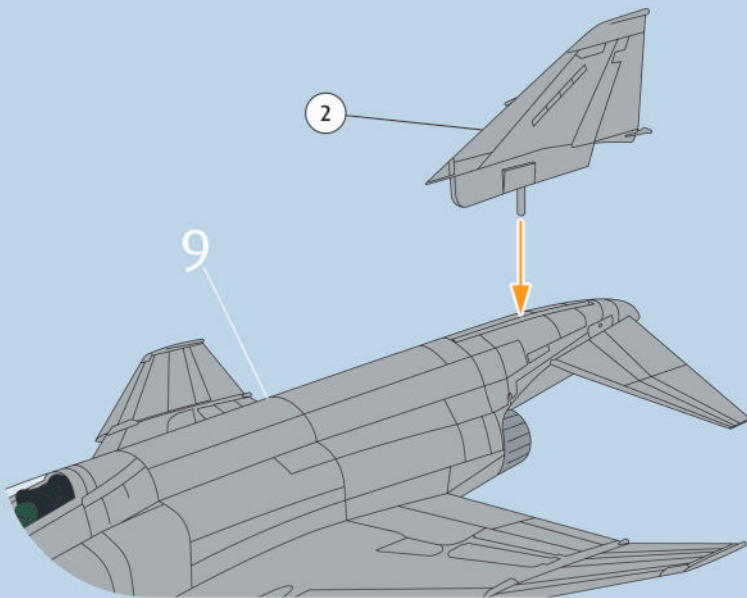

11

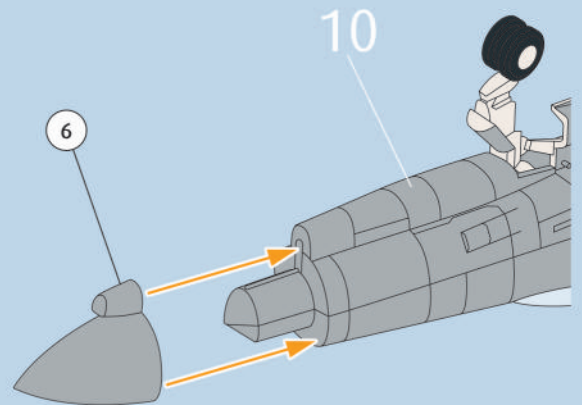
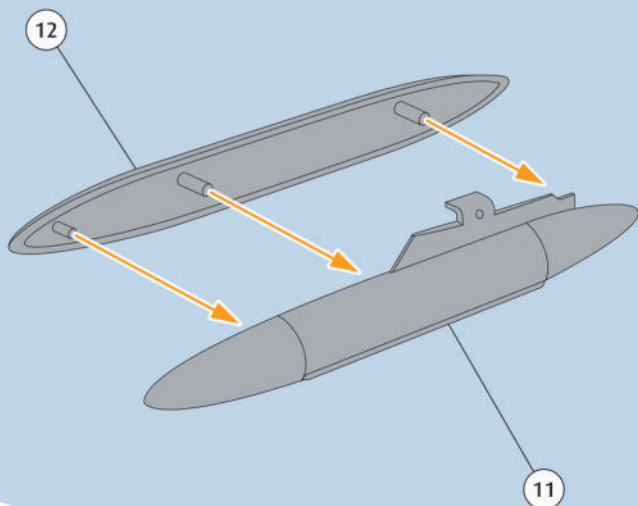
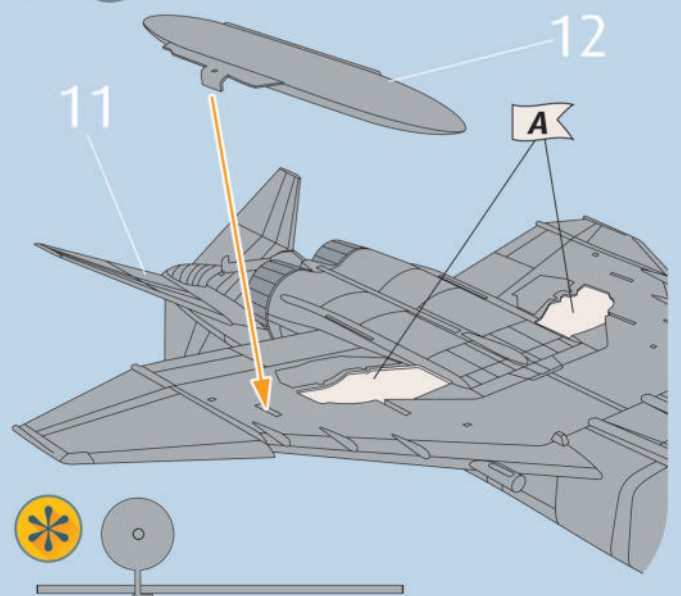
12 **2X**13 

14

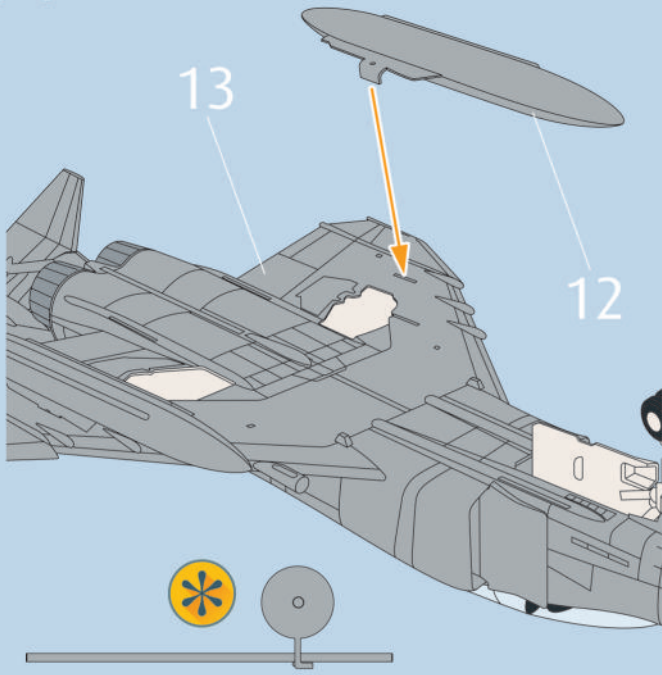

15

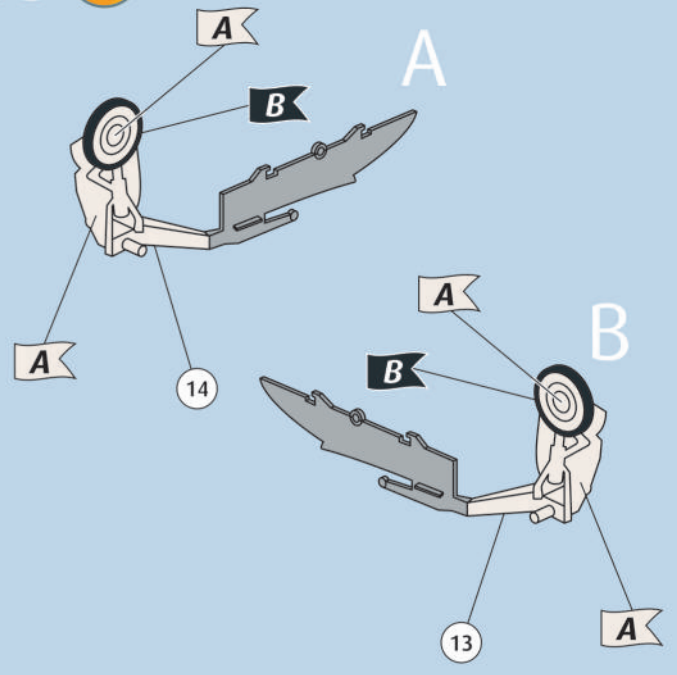

16

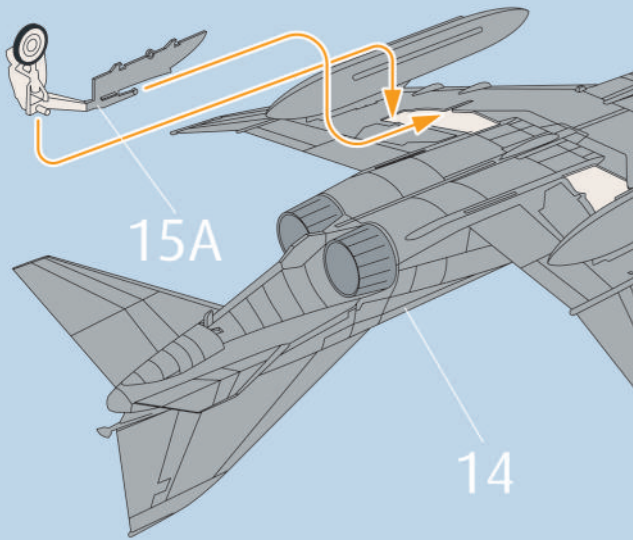

17

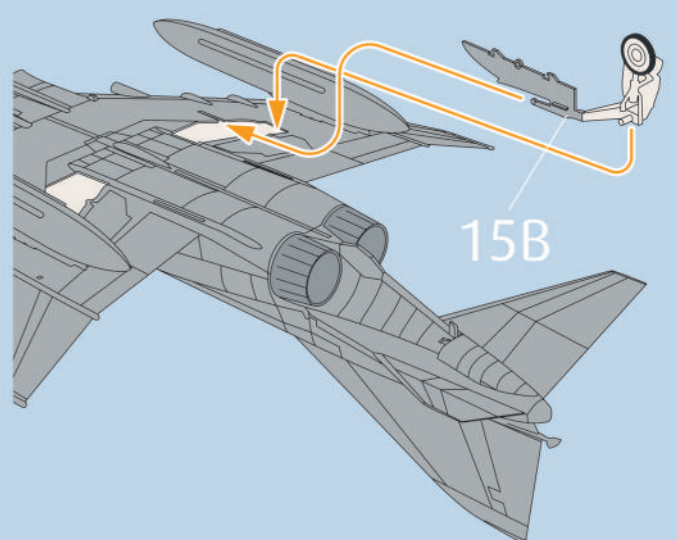

18

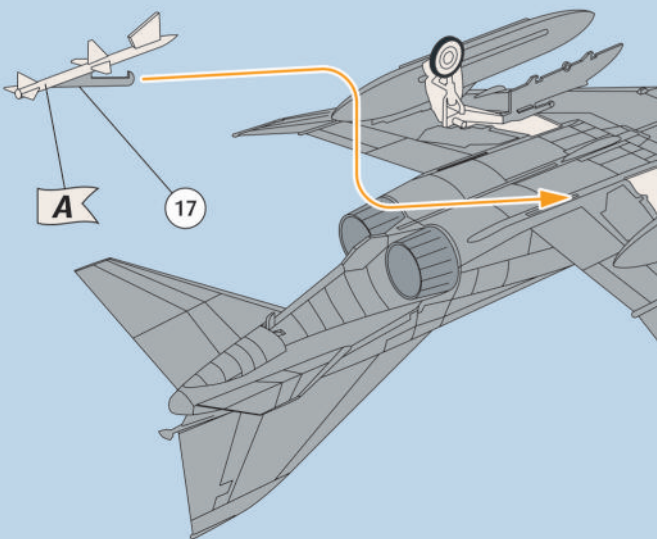

19

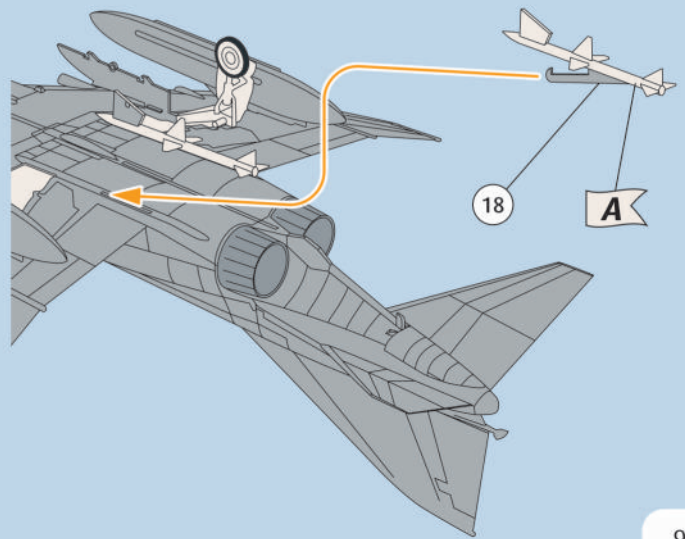

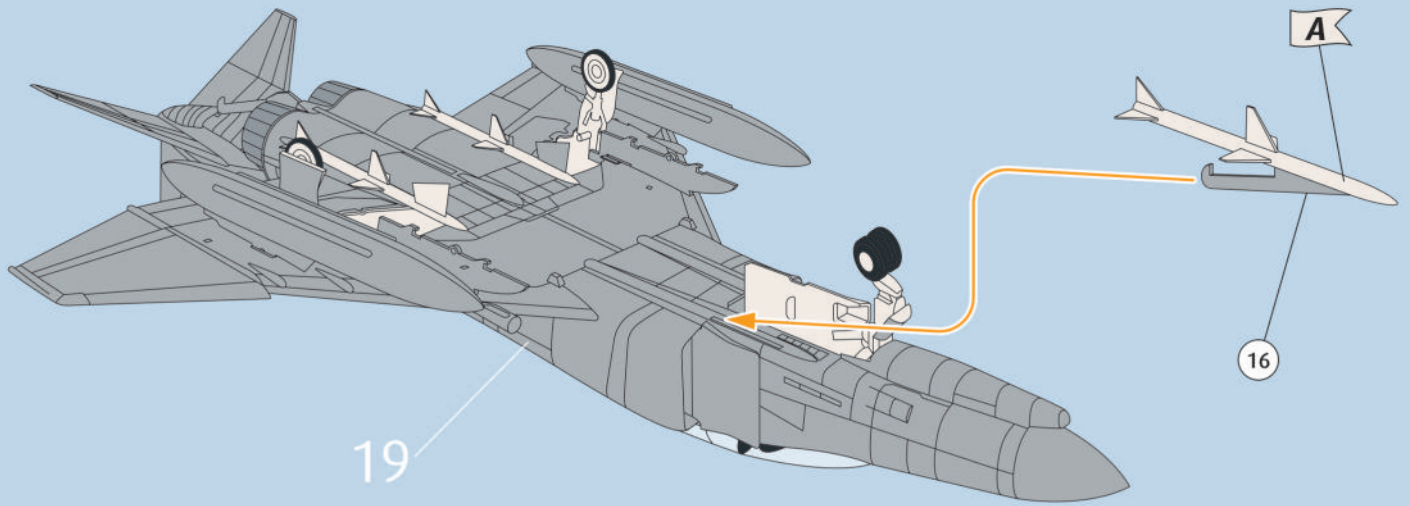
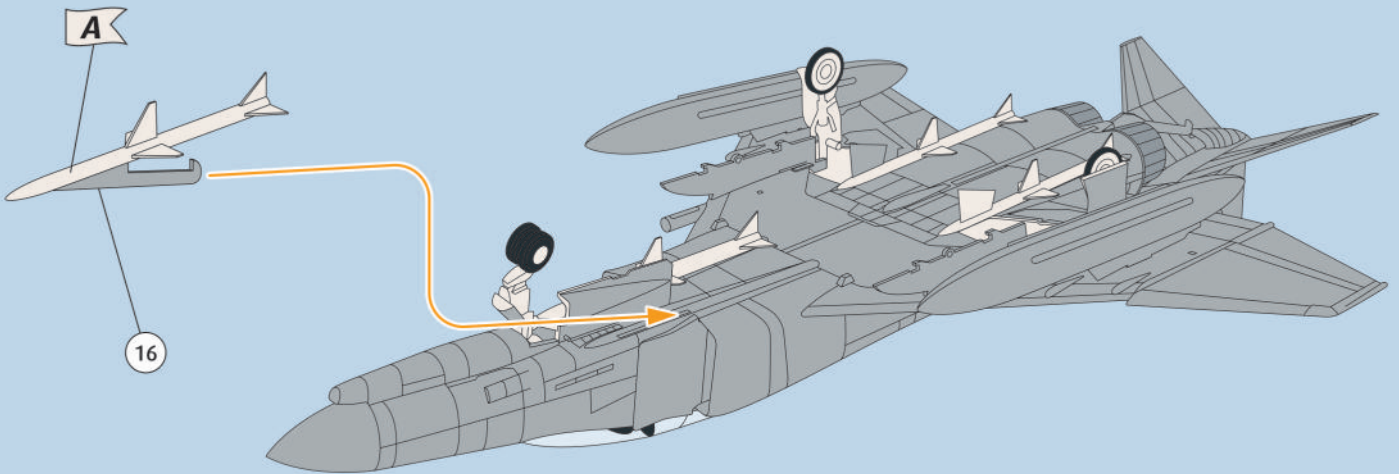
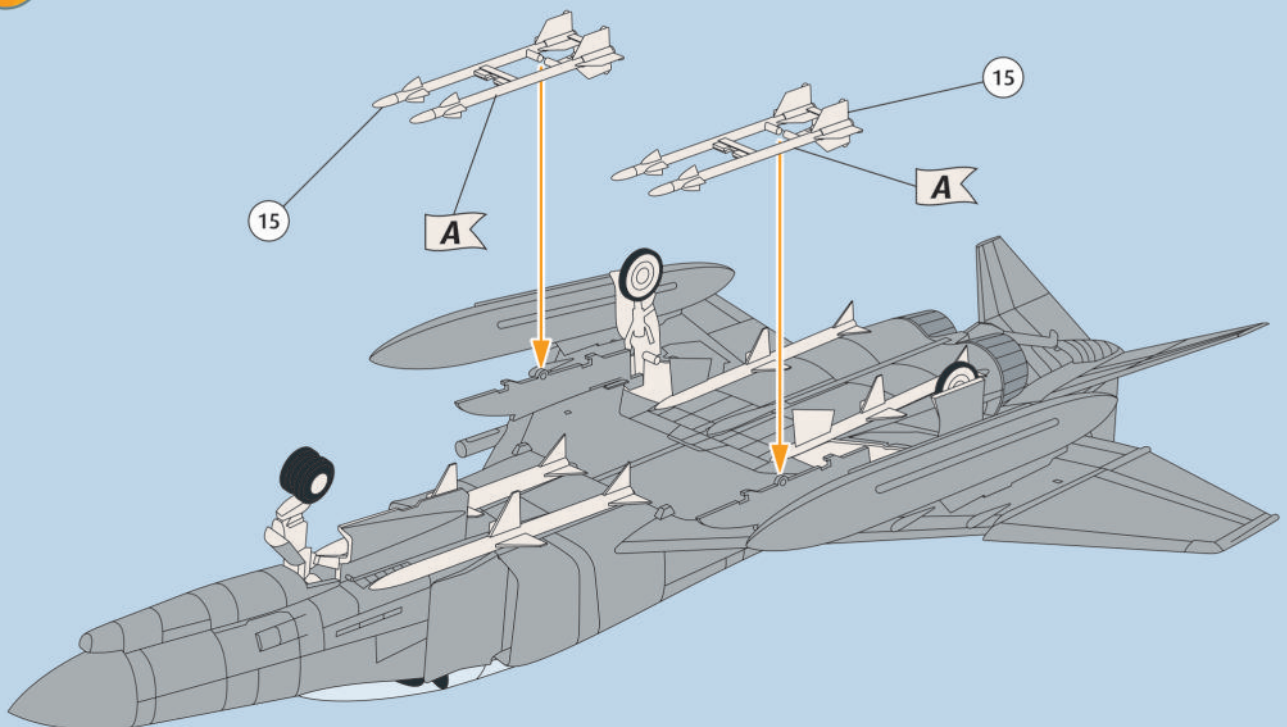
20 21 22 

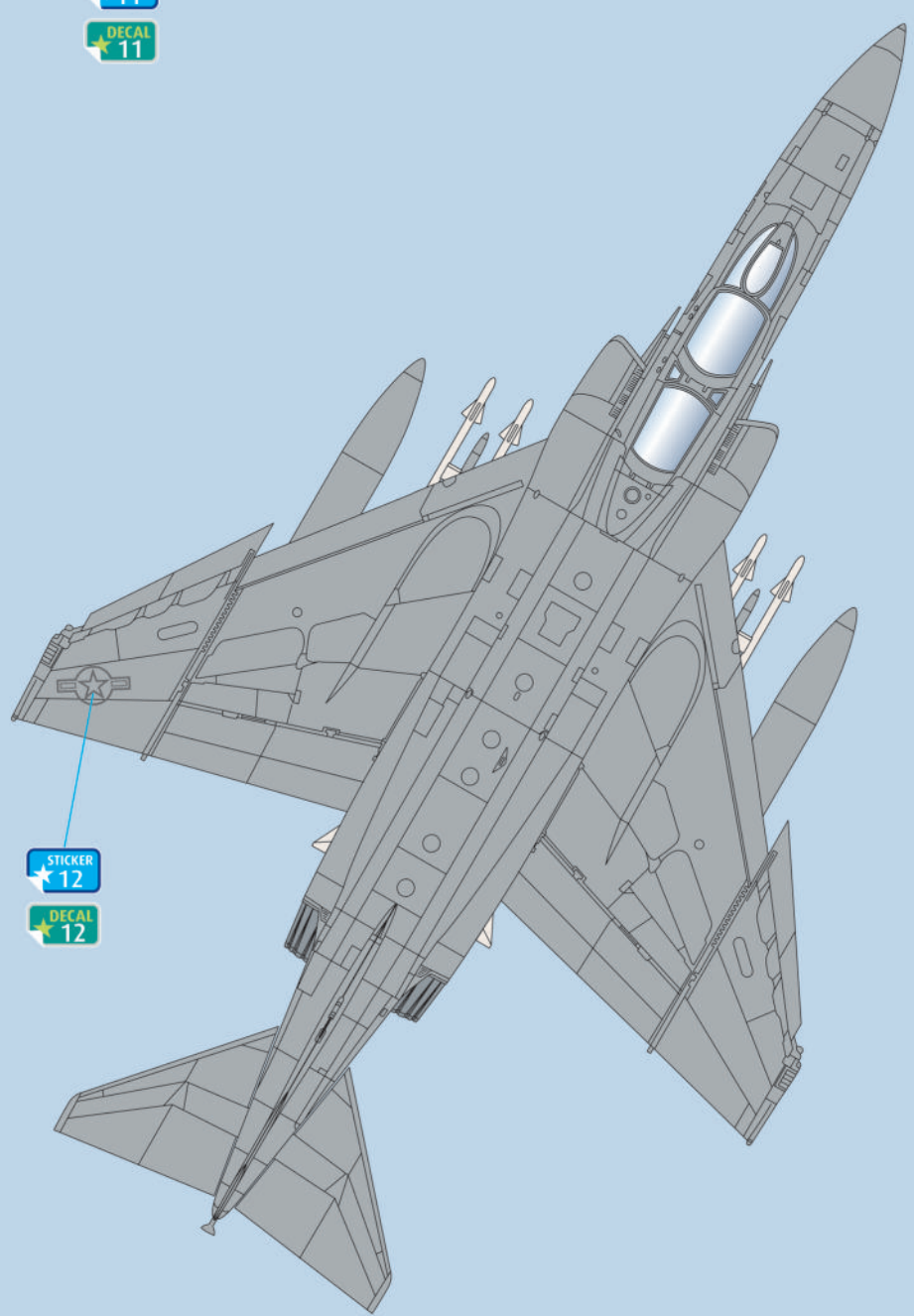
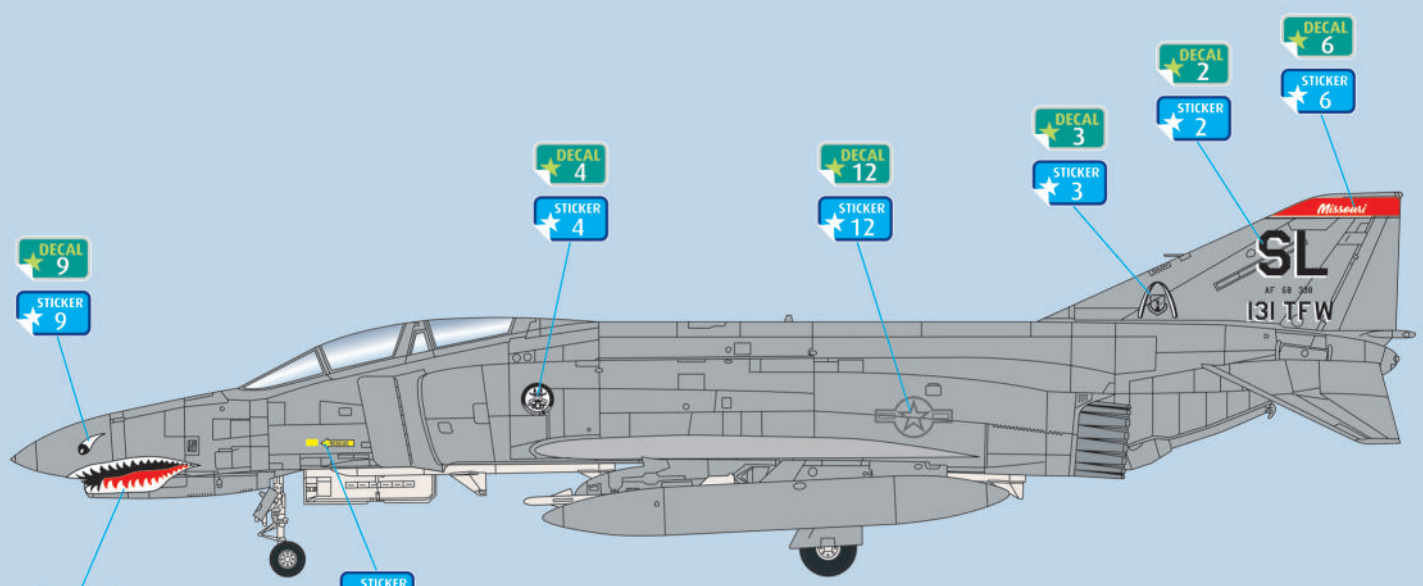

Missouri
SL
 AF 68 360
 131 TFW

