



07050-0379

LEVEL 5

1 2 3 4 5



VW T1

SAMBA BUS FLOWER POWER

Beiliegenden Sicherheitstext beachten / Please note the enclosed safety advice

- Ⓢ Beiliegenden Sicherheitstext beachten und nachschlagbereit halten.
- Ⓢ Please note the enclosed safety advice and keep safe for later reference.
- Ⓢ Respecter les consignes de sécurité ci-jointes et les conserver à portée de main.
- Ⓢ Houdt u aan de bijgaande veiligheidsinstructies en hou deze steeds bij de hand.
- Ⓢ Seguire le avvertenze di sicurezza allegate e tenerle a portata di mano.
- Ⓢ Observar y siempre tener a disposición este texto de seguridad adjunto.
- Ⓢ Ter em atenção o texto de segurança anexo e guardá-lo para consulta.

- Ⓢ Overhold vedlagte sikkerhedsanvisninger og hav dem liggende i nærheden.
- Ⓢ Ha alltid vedlagt sikkerhetstekst klar til bruk.
- Ⓢ Beakta bifogad säkerhetstext och håll den i beredskap.
- Ⓢ Huomioi ja säilytä oheiset varoitukset.
- Ⓢ Соблюдать технику безопасности, сохранить инструкцию для дальнейших обращений.
- Ⓢ Przestrzegać załączonego tekstu dotyczącego bezpieczeństwa i mieć go zawsze pod ręką.
- Ⓢ Dodržujte tento priložený bezpečnostní text a mějte ho po ruce.
- Ⓢ A mellékelt biztonsági szöveget vegye figyelembe és tartsa fellepozásra készen.

- Ⓢ Respektujte priložený bezpečnostný text a uchovajte ho pre budúce použitie.
- Ⓢ Respectați textul de siguranță atașat și păstrați-l la îndemână.
- Ⓢ Спазвайте приложенія текст за безопасност и го дръжте под ръка за справки.
- Ⓢ Priložena varnostna navodila izvajajte in jih hranite na vsem dostopnem mestu.
- Ⓢ Λάβετε υπόψη σας το συννημένο κείμενο ασφαλείας και φυλάξτε το ώστε να ανατρέχετε σε αυτό όποτε χρειάζεται.
- Ⓢ Ektekigüvenlik talimatlarını dikkate alıp, bakabileceğiniz bir şekilde muafaza ediniz.



☞ Weitere Tipps und Tricks.
 ☞ Additional tips and tricks.
 ☞ Conseils et astuces supplémentaires.
 ☞ Andere tips en trucs.
 ☞ Ulteriori consigli e suggerimenti.
 ☞ Consejos y sugerencias adicionales.
 ☞ Mais dicas e truques.

☞ Flere tips og tricks.
 ☞ Flere tips og tricks.
 ☞ Ytterligare tips och tricks.
 ☞ Lisää vinkkejä ja niksejä.
 ☞ Другие советы и хитрости.
 ☞ Dalsze wskazówki i sugestie.
 ☞ Další tipy a rady.
 ☞ További ötletek és fogások.
 ☞ Dalsie tipy a triky.
 ☞ Alte sfaturi și trucuri.

☞ Други полезни съвети и трикове.
 ☞ Nadaljnji nasveti in zvižaje.
 ☞ Πρόσθετες συμβουλές και κόλπα.
 ☞ Diğer öneriler ve ipuçları.

www.revell.de



DE Kleben
 GB Glue
 FR Coller
 NL Lijmen
 IT Incollare
 ES Pegamento
 PT Colar
 DK Lim
 NO Lime
 SE Limma
 FI Liimaa
 RU Kleить
 PL Przykleić
 CZ Slepění
 HU Ragassza rá
 SK Lepiť
 RO Lipiți
 BG Зелепете
 SI Prilepite
 GR Κολλήσετε
 TR Yapıştırma



DE Nicht kleben
 GB Don't glue
 FR Ne pas coller
 NL Niet lijmen
 IT Non incollare
 ES No pegamento
 PT Não colar
 DK Lim ikke
 NO Ikke lime
 SE Limma inte
 FI Älä liimaa
 RU Не клеить
 PL Nie przyklejać
 CZ Nelepít
 HU Ne ragassza rá
 SK Nelepíť
 RO Nu lipiți
 BG Не лепете
 SI Ne lepíte
 GR Μην κολλήσετε
 TR Yapıştırmayın



DE Bemalen
 GB Paint
 FR Peindre
 NL Beschilderen
 IT Colorare
 ES Pintar
 PT Pintar
 DK Mal
 NO Male
 SE Måla
 FI Maalaa
 RU Раскрасить
 PL Pomalować
 CZ Pomalovat
 HU Fesse be
 SK Natriť
 RO Vopsiți
 BG Боядисайте
 SI Robarvajte
 GR Βάψτε
 TR Boyama



DE Zusammenbau Reihenfolge.
 GB Sequence of assembly.
 FR Ordre d'assemblage.
 NL Volgorde van montage.
 IT Sequenza di assemblaggio.
 ES Secuencia de montaje.
 PT Sequência de montagem.
 DK Samlerækkefølge.
 NO Monteringsrekkefølge.
 SE Montering ordningsföljd.
 FI Kokoamisjärjestys.
 RU Последовательность сборки.
 PL Kolejność montażu.
 CZ Pořadí složení.
 HU Összerakási sorrend.
 SK Poradie zostavenia.
 RO Ordinea asamblării.
 BG Последователност на сглобяване.
 SI Vrstni red sestavljanja.
 GR Σειρά τοποθέτησης.
 TR Parçaları birleştirme sırası.



DE Wahlweise
 GB Optional
 FR Facultatif
 NL Naar keuze
 IT Facoltativamente
 ES Opcional
 PT Opcional
 DK Valgfri
 NO Valgfritt
 SE Valfri
 FI Valinnaisesti
 RU На выбор
 PL Opcjonalnie
 CZ Volitelně
 HU Választás szerint
 SK Alternatívne
 RO Opțional
 BG По избор
 SI Izbirno
 GR Προαιρετική
 TR Opsiyonel



DE Klarsichtteile
 GB Clear parts
 FR Pièces transparentes
 NL Transparente onderdelen
 IT Parti trasparenti
 ES Piezas transparentes
 PT Peças transparentes
 DK Klare dele
 NO Klare deler
 SE Genomsiktliga detaljer
 FI Läpinäkyvät osat
 RU Прозрачные детали
 PL Przejroczyste części
 CZ Průhledné díly
 HU Átlátszó alkatrészek
 SK Číre diely
 RO Piese transparente
 BG Прозрачни части
 SI Prozorni deli
 GR Διαφανή μέρη
 TR Şeffaf parçalar



DE Anzahl der Arbeitsgänge.
 GB Number of working steps.
 FR Nombre d'étapes de travail.
 NL Het aantal bouwstappen.
 IT Numero di fasi di lavoro.
 ES Número de pasos de trabajo.
 PT Número de passos de trabalho.
 DK Antal arbejds-gange.
 NO Antall arbeidstrinn.
 SE Antal operationer.
 FI Työvaiheiden määrä.
 RU Количество операций.
 PL Liczba cykli roboczych.
 CZ Počet pracovních kroků.
 HU A munkamenetek száma.
 SK Počet pracovných operácií.
 RO Numărul etapelor de lucru.
 BG Брой работни стъпки.
 SI Število delovnih postopkov.
 GR Αριθμός βημάτων εργασίας.
 TR Çalışma adımı sayısı.



DE Achtung
 GB Attention
 FR Attention
 NL Obgelet
 IT Attenzione
 ES Atención
 PT Atenção
 DK Obs!
 NO OBS
 SE OBS
 FI Huomio
 RU Внимание
 PL Uwaga
 CZ Pozor
 HU Figyelem!
 SK Pozor
 RO Atenție
 BG Внимание
 SI Pozor
 GR Προσοχή
 TR Dikkat



DE Bauteile trocknen lassen.
 GB Allow the parts to dry.
 FR Laisser sécher les pièces.
 NL Ouderdelen laten drogen.
 IT Lasciare asciugare i componenti.
 ES Dejar secar las piezas.
 PT Deixar as peças secar.
 DK Lad delene tørre.
 NO Tørk komponenter.
 SE Låt komponenterna torka.
 FI Anna rakenneseosien kuivua.
 RU Дайте деталям высохнуть.
 PL Pozostawić elementy konstrukcji do wyschnięcia.
 CZ Nechte díly uschnout.
 HU Hagyja megszáradni az alkatrészeket.
 SK Konštrukčné diely nechajte vyschnúť.
 RO Lăsați componentele să se usuce.
 BG Оставете съглобените части да изсъхнат.
 SI Osušite sestavne dele.
 GR Αφήστε τα μέρη να στεγνώσουν.
 TR Yapı parçalarını kurumaya bırakın.



DE Abziehbild in Wasser einweichen und anbringen.
 GB Soak and apply decals.
 FR Mouiller et appliquer les décalcomanies.
 NL Transfer in water even laten weken en aanbrengen.
 IT Immergere la decalomania nell'acqua e applicarla.
 ES Mojar y aplicar calcomanías.
 PT Amolecer o decalque em água e aplicar.
 DK Gør overføringsbilledet vådt og sæt det på.
 NO Myk opp avtrekkingsbildet i vann og sett på.
 SE Blötlägg dekalen i vatten och sätt på den.
 FI Pehmitä siirtokuva vedessä ja siirrä paikalleen.
 RU Опустите переводную картинку в воду и нанесите её.
 PL Namoczyć kalkomanie w wodzie i przykleić.
 CZ Nechte obtisk odmočit ve vodě a přilepte.
 HU Merítse vízbe és helyezze fel a matricát.
 SK Oblačkový obrázok namočte do vody a priložte na plochu.
 RO Inmuiați abțibildul în apă și aplicați-l.
 BG Потопете ваденката във вода и я поставете.
 SI Prelepnico namakajte v vodi. In nameslite.
 GR Μουσκεψτε σε νερό και τοποθετήστε τις χαλκομανίες.
 TR Çıkartmayı suda yumuşatın ve takın.



DE Chrom entfernen.
 GB Remove chrome.
 FR Enlever le chrome.
 NL Chrom verwijderen.
 IT Rimuovere il cromo.
 ES Quitar cromado.
 PT Remover o cromo.
 DK Fjern kromen.
 NO Fjern krom.
 SE Ta bort kromet.
 FI Kromin poisto.
 RU Удалить хром.
 PL Usunąć chrom.
 CZ Chrom odstráňte.
 HU Távolítsa el a krómot.
 SK Odstráňte chróm.
 RO Îndepărtați cromul.
 BG Отстраняване на хрома.
 SI Odstranitev kroma.
 GR Αφαιρέστε το χρώμιο.
 TR Kromu çıkarm.



DE Spitze eines Schraubenziehers erhitzen und auf das herausragende Ende des Plastikstiftes drücken.
 GB Heat tip of screwdriver and press on protruding end of plastic pin.
 FR Chauffer la pointe du tournevis et appuyer sur la partie saillante de l'extrémité en plastique.
 NL De punt van een schroevendraaier verhitten en op het uitstekende einde van de plastic stift drukken.
 IT Riscaldare la punta di un cacciavite e premere sull'estremità sporgente del perno di plastica.
 ES Calentar la punta del destornillador y presionar el extremo saliente de la clavija de plástico.
 PT Aquecer a ponta de uma chave de parafusos e pressionar sobre a extremidade protuberante do pino plástico.
 DK Opvarm spidsen af en skruetrækker og tryk på den udtrækkende ende af plastikstiften.
 NO Varm opp spissen på en skrutrekker og trykk på den utstikkende enden av plaststiften.
 SE Värm toppen av en skruvmejsel och tryck den på plaststiftens utstickande ände.
 FI Kuumenna ruuvimeisselin päätä ja paina esiintyntyvän muovipivikon päätä.
 RU Нагреть наконечник отвертки и надавить на выступающий конец пластмассового штифта.
 PL Ogrzać czubek śrubokrętu i przycisnąć do końcówki wystającego plastikowego kolka.
 CZ Nahřejte špičku šroubováku a přitiskněte ji na vyčnívající konec plastového kolíka.
 HU Melegítse meg a csavarhúzó hegyét és nyomja rá a műanyag csap kiálló végére.
 SK zohrejte hrot skrutkovača a zatlačte na vyčnievajúci koniec plastového kolíka.
 RO Încălziți vârful unei șurubelnițe și apăsați pe capătul proeminent al știftului de plastic.
 BG Нагрейте върха на отвертка и натиснете подаващия се край на пластмасовия щифт.
 SI Konic izvijaca segrejte in pritisnite na izstopajoči konec plastičnega zatiča.
 GR Θερμάνετε την άκρη ενός κατσαβιδίου και πιέστε στο άκρο του πλαστικού πείρου που προεξέχει.
 TR Tornavidanın ucunu ısıtın ve plastik pimini çıkıntı yapan ucuna tutun.



DE Wegfeilen
 GB File off
 FR Enlever avec une lime
 NL Wegvijlen
 IT Rimuovere con una lima
 ES Limar
 PT Remover com uma lima
 DK Fil af
 NO File av
 SE Skall filas bort
 FI Hio pois
 RU Сточить напильником
 PL Odpilować
 CZ Odpiľovať
 HU Reszelje le
 SK Odpiľovať
 RO Piliiți
 BG Изпилете
 SI Odrpilite
 GR Λιμάρετε
 TR Zımparalama



DE Öffnungen mit Spachtelmasse verschließen und Oberfläche mit Schleifpapier angleichen.
 GB Close openings with putty and sand down surface.
 FR Reboucher les orifices avec du mastic et uniformiser les surfaces avec du papier à poncer.
 NL Dicht de openingen af met plamuur en maak het oppervlak glad met schuurpapier.
 IT Chiudere le aperture con del mastic e uniformare la superficie utilizzando della carta vetrata.
 ES Cerrar los extremos con masilla y lijar la superficie.
 PT Fechar as aberturas com argamassa e alisar a superfície com uma lixa.
 DK Luk åbningerne med spartelmasse, og slib overfladen i venstre side ned.
 NO Lukk åpningene med sparkelmasse og jevn ut overflaten med sliperpapier.
 SE Förslut öppningarna med spackelfärg och jämna till ytan med slippapper.
 FI Sulje aukot pakkelilla ja tasoita yläpinta hiekkaperillä.
 RU Заделать отверстия шпаклёвкой и выровнять поверхность нужданной бумагой.
 PL Zapieścić otwory masą szpachlową i wyrównać powierzchnię, używając papieru ściernego.
 CZ Otvory uzavřete tmelem a povrch vybruste brusným papírem.
 HU Zárja le a nyílásokat glettenyaggal, és a felületet simítsa le csiszolópapírral.
 SK Otvory vyplňte tmeliacou hmotou a povrch vyrovnaťte brusným papierom.
 RO Închideți orificiile cu material de spăcluit și șlefuiți suprafața cu hârtie abrazivă.
 BG Китвайте отворите и изравнете повърхността с шкурка.
 SI Odrpitino zaprite z maso-lopatico in izravnajte površino z brusnim papirjem.
 GR Κλείστε ανοίγματα με στόκο και ζύστε την επιφάνεια με υαλοχαρτό.
 TR Boşlukları macun ile kapatın ve yüzeyi zımpara kağıdı ile düzleştirin.



DE Gleichen Vorgang auf der gegenüberliegenden Seite wiederholen.
 GB Repeat same procedure on opposite side.
 FR Opérer de la même façon sur l'autre face.
 NL Dezelfde handeling herhalen aan de tegenoverliggende kant.
 IT Ripetere il procedimento dall'altra parte.
 ES Repetir el mismo procedimiento en el lado contrario.
 PT Repetir alguns procedimentos no lado oposto.
 DK Gentag proceduren på den modstående side.
 NO Gjenta samme forlop på motsatt side.
 SE Upprepa samma process på motsatta sidan.
 FI Toista menettely vastakkaisella puolella.
 RU Повторить такие же действия на противоположной стороне.
 PL Powtórzć te same czynności po przeciwnej stronie.
 CZ Stejný postup opakujte na protilehlé straně.
 HU Ismétlje meg a műveletet az ellentétes oldalon.
 SK Rovnaký postup zopakujte na protilohéj strane.
 RO Repetați același procedeu pe latura opusă.
 BG Повторете същите стъпки на срещуположната страна.
 SI Enak postopek ponovite na nasprotni strani.
 GR Επανάλαβετε την ίδια διαδικασία στην αντίθετη πλευρά.
 TR Aynı işlem adimlarını diğer tarafta da uygulayın.



- DE Papierbild ausschneiden und kleben.
- EN Cut out paper picture and glue.
- FR Découper la photo et la coller.
- NL Papiertekening uitknippen en lijmen.
- IT Ritagliare l'immagine di carta e incollarla.
- ES Recortar la imagen de papel y pegar.
- PT Recortar a imagem de papel e colar.
- DE Klip papirbilledet ud og lim det.
- NO Klippe ut papirbilde og lime.
- SE Klipp ut och limma pappersbild.
- FI Leikkaa ja liimaa paperikuva.
- RU Вырезать и приклеить бумажную картинку.
- PL Wyciąć papierowy obrazek i przykleić.
- CZ Vystřihněte papírový obrázek a nalepte.
- HU Vágja ki és ragassza rá a papírképet.
- SK Vystrihnite papierový obrázok a nalepte.
- RO Decupați imaginea pe hârtie și lipiți-o.
- DE Изрежете и залепете хартиената картинка.
- GR Изреžite papirno sliko in prilepite.
- GR Κόψτε τη χαρτινή εικόνα και κολλήστε την.
- TR Kağıt resmi kesin ve yapıştırın.



- DE Bauanleitung sorgfältig lesen.
- EN Read the assembly instructions carefully.
- FR Lisez attentivement les instructions de montage.
- NL Bouwinstructies zorgvuldig doorlezen.
- IT Leggere attentamente le istruzioni per il montaggio.
- ES Lea cuidadosamente las instrucciones de montaje.
- PT Ler atentamente as instruções de montagem.
- DE Læs byggevejledningen omhyggeligt.
- NO Les byggeanvisningen nøye.
- SE Monteringsinstruktionerna skall läsas noggrant.
- FI Lue kokoamisohje huolellisesti.
- RU Внимательно прочитайте инструкцию по сборке.
- PL Dokładnie przeczytać instrukcję montażu.
- CZ Přečtěte si pečlivě návod k obsluze.
- HU Figyelmesen olvassa el a szerelési útmutatót.
- SK Návod na montáž starostlivo prečítajte.
- RO Citiiți cu atenție instrucțiunile de montare.
- DE Прочетете внимателно упу̀тването за монтаж.
- GR Σkrbno preberite navodila za sestavo.
- GR Διαβάστε προσεκτικά τις οδηγίες κατασκευής.
- TR Yapı kilavuzunu dikkatle okuyun.



- DE Zur Anbringung der Abziehbilder empfohlen.
- EN Recommended for affixing the decals.
- FR Recommandé pour l'application des décalcomanies.
- NL Aanbevolen voor het aanbrengen van de transfers.
- IT Raccomandato per l'applicazione delle decalcomanie.
- ES Recomendado para fijar bien las calcomanías.
- PT Recomendado para a fixação dos autocolantes.
- DE Anbefales til anbringelse af overføringsbillederne.
- NO Anbefales til å feste avtrekksbilder.
- SE Rekommenderad för montering av klisterdekalerna.
- FI Suositellaan siirtokuvien siirtämiseen.
- RU Рекомендуется для нанесения переводных картинок.
- PL Zalecane do przyklejenia kalkomanii.
- CZ Doporučujeme k umístění obtiskovacích obrázků.
- HU A matrica felhelyezéséhez ajánlható.
- SK Odporúčame sa pre umiestnenie obtlačkových obrázků.
- RO Recomandat pentru aplicarea abțibildurilor.
- DE Препоръчва се за поставяне на воденки.
- GR При namešćanju nalepnice priporočamo.
- GR Συνιστάται για την τοποθέτηση των χαλκομανιών.
- TR Çikartmaların takılması için önerilir.



- DE Zur Anbringung der Chromteile empfohlen.
- EN Recommended for attaching the chrome parts.
- FR Conseillé pour le montage des pièces chromées.
- NL Aanbevolen voor monteren chromdelen.
- IT Consigliato per applicare le parti cromate.
- ES Recomendado para la fijación de piezas de cromo.
- PT Recomendado para a aplicação das peças em cromo.
- DE Anbefales til placering af kromdelene.
- NO Anbefales til montering av kromdeler.
- SE Rekommenderad för montering av kromdetaljerna.
- FI Suositellaan kromiosien siirtämiseen.
- RU Рекомендуется для крепления хромированных деталей.
- PL Zalecane do mocowania elementów chromowanych.
- CZ Doporučujeme umístění chromových dílů.
- HU A króm darabok felhelyezéséhez ajánlott.
- SK Odporúča sa pre umiestnenie chrómových dielov.
- RO Recomandat pentru atașarea pieselor din crom.
- DE Препоръчва се за поставяне на хромови части.
- GR При namešćanju kromiranih delov priporočamo.
- GR Συνιστάται για την τοποθέτηση των εξαρτημάτων χρωμίου.
- TR Krom parçaların yapıştırılması için önerilir.



- DE Zur Anbringung der Klarteile empfohlen.
- EN Recommended to fix clear parts.
- FR Recommandé pour fixer les pièces transparentes.
- NL Aanbevolen voor het aanbrengen van transparante delen.
- IT Raccomandato per l'applicazione delle parti trasparenti.
- ES Recomendado para fijar las piezas transparentes.
- PT Recomendado para a aplicação das peças transparentes.
- DE Anbefales til anbringelse af de klare dele.
- NO Anbefales til å feste klare deler.
- SE Rekommenderad för montering av de genomskinliga detaljerna.
- FI Suositellaan läpinäkyvien osien siirtämiseen.
- RU Рекомендуется для крепления прозрачных деталей.
- PL Zalecane do przyklejenia przezroczystych części.
- CZ Doporučujeme k umístění průhledných dílů.
- HU Az átlátszó darabok felhelyezéséhez ajánlható.
- SK Odporúča sa pre umiestnenie čírych dielov.
- RO Recomandat pentru aplicarea pieselor transparente.
- DE Препоръчва се за поставяне на прозрачни части.
- GR При namešćanju prozornih delov priporočamo.
- GR Συνιστάται για την τοποθέτηση των διάφανων μερών.
- TR Şeffaf parçaların takılması için önerilir.



- DE Nicht enthalten
- EN Not included
- FR Non fourni
- NL Behoort niet tot de levering
- IT Non incluso
- ES No incluido
- PT Não incluído
- DE Medfølger ikke
- NO Ikke inkludert
- SE Ingår ej
- FI Ei sisällä
- RU Не содержится
- PL Nie wchodzi w zakres dostawy
- CZ Není obsaženo
- HU Nem tartalmazza
- SK Neobsahuje
- RO Nu este inclus
- DE Не се включва в комплекта
- GR Ni priloženo
- GR Δεν περιλαμβάνεται
- TR İçermiyor

Benötigte Farben / Required colours

FR Peintures nécessaires
NL Benodigde kleuren
IT Colori necessari
ES Colores necesarios
PT Cores necessárias
DK Nødvendige farver
NO Nødvendige farger
SE Erforderliga färger
FI Tarvittavat värit
RU Необходимые краски
PL Potrzebne kolory
CZ Potřebné barvy
HU Szükséges színek
SK Požadované farby
RO Culori necesare
BG Необходими цветове
SI Potrebne barve
GR Απαιτούμενα χρώματα
TR Gerekl renkler

99

A

DE Aluminium metallic
GB Aluminium metallic
FR Aluminium métallique
NL Aluminium metallic
IT Alluminio metallico
ES Aluminio metálico
PT Aluminio metálico
DK Aluminium metallisk
NO Aluminium metallic
SE Aluminium metallic
FI Alumiini metallinen
RU Алюминий металлик
PL Aluminium metaliczny
CZ Hliníková metalizový
HU Alumínium metál
SK Hliníková metaliza
RO Aluminiiu metallic
BG Алюминий металик
SI Aluminijasta kovinska
GR Αλουμίνιο μεταλλικό
TR Alüminyum grisi metalik

302

B

DE Schwarz seidenmatt
GB Black silk matt
FR Noir satiné mat
NL Zwart zijdemat
IT Nero opaco satinato
ES Negro mate satinado
PT Preto mate sedoso
DK Sort silkematt
NO Sort silkematt
SE Svart sidenmatt
FI Musta silkkimatta
RU Чёрный шелковисто-матовый
PL Czarny jedwabiscie matowy
CZ Černá jemně matný
HU Fekete, fakóselymes
SK Čierna hodvábne matný
RO Negru satinat
BG Черно коприненоматово
SI Črna svileni-mat
GR Μαύρο σατινέ
TR Siyah ipeksi mat

90

C

DE Silber metallic
GB Silver metallic
FR Argent métallique
NL Zilver metallic
IT Argento metallico
ES Plata metálico
PT Prata metálico
DK Sølv metallisk
NO Sølv metallic
SE Silver metallic
FI Hopea metallinen
RU Серебрянный металлик
PL Srebrny metaliczny
CZ Stříbrná metalizový
HU Ezüstmetál
SK Strieborná metaliza
RO Argintiu metallic
BG Сребро металик
SI Srebrna kovinska
GR Ασημί μεταλλικό
TR Gümüş rengi metalik

09

D

DE Anthrazit matt
GB Anthracite matt
FR Anthracite mat
NL Antraciet mat
IT Antracite opaco
ES Antracita mate
PT Antracite mate
DK Antracitgrå mat
NO Antrasitt matt
SE Antracitgrå matt
FI Antrasiiinharmaa matta
RU Антрацит матовый
PL Antracyt matowy
CZ Antracitová šedá matný
HU Antracit, fénytelen
SK Čierna uhľová matný
RO Antracit mat
BG Антрацит матово
SI Antracit mat
GR Γκρι ανθρακί ματ
TR Antrazit mat

91

E

DE Eisen metallic
GB Iron metallic
FR Fer métallique
NL IJzer metallic
IT Ferro metallico
ES Acero metálico
PT Aço metálico
DK Stål metallisk
NO Jern metallic
SE Stål metallic
FI Teräs metallinen
RU Сталь металлик
PL Grafit metaliczny
CZ Ocelová metalizový
HU Acélmetál
SK Ocelová metaliza
RO Fier metallic
BG Желязо металик
SI Železna kovinska
GR Χρώμα σιδήρου μεταλλικό
TR Metalik metalik

50

F

DE Lichtblau glänzend
GB Light blue gloss
FR Bleu clair brillant
NL Lichtblauw glanzend
IT Blu luce lucido
ES Azul claro brillante
PT Azul claro brilhante
DK Lyseblå blank
NO Lyseblå glansende
SE Lysande blå blank
FI Vaaleansininen kiiltävä
RU Светло-синий глянец
PL Rozświetlony niebieski błyszczący
CZ Světla modrá lesklý
HU Halványkék, fényes
SK Svetlo modrá lesklý
RO Albastru-deschis strălucitor
BG Лъчистосиньо глянцово
SI Svetlo-modra sijoca
GR Μπλε ανοιχτό γυαλιστερό
TR Açık mavi parlak

382

G

DE Holzbraun seidenmatt
GB Wood brown silk matt
FR Brun bois satiné mat
NL Houtbruin zijdemat
IT Marrone legno opaco satinato
ES Marrón madera mate satinado
PT Castanho madeira mate sedoso
DK Træbrun silkematt
NO Trebrun silkematt
SE Tråbrun sidenmatt
FI Puunruskea silkkimatta
RU Древесно-коричневый шелковисто-матовый
PL Brązowy w odcieniu drewna jedwabiscie matowy
CZ Dřevěná hnědá jemně matný
HU Fa barna, fakóselymes
SK Drevená hnedá hodvábne matný
RO Maro lemnos satinat
BG Дървеснокафяво коприненоматово
SI Lesno-rjava svileni-mat
GR Καφέ ανοιχτό σατινέ
TR Aşşap rengi ipeksi mat

04

H

DE Weiß glänzend
GB White gloss
FR Blanc brillant
NL Wit glanzend
IT Bianco lucido
ES Blanco brillante
PT Branco brilhante
DK Hvid blank
NO Hvit glansende
SE Vit blank
FI Valkoinen kiiltävä
RU Белый глянец
PL Biały błyszczący
CZ Bílá lesklý
HU Fehér, fényes
SK Biela lesklý
RO Alb strălucitor
BG Бяло глянцово
SI Bela sijoca
GR Άσπρο γυαλιστερό
TR Beyaz parlak

374

I

DE Grau seidenmatt
GB Grey silk matt
FR Gris satiné mat
NL Grijs zijdemat
IT Grigio opaco satinato
ES Gris mate satinado
PT Cinzento mate sedoso
DK Grå silkematt
NO Grå silkematt
SE Grå sidenmatt
FI Harmaa silkkimatta
RU Серый шелковисто-матовый
PL Szary jedwabiscie matowy
CZ Šedá jemně matný
HU Szürke, fakóselymes
SK Sivá hodvábne matný
RO Gri satinat
BG Сиво коприненоматово
SI Siva svileni-mat
GR Γκρι σατινέ
TR Gri ipeksi mat

371

J

DE Hellgrau seidenmatt
GB Light grey silk matt
FR Gris clair satiné mat
NL Lichtgrijs zijdemat
IT Grigio chiaro opaco satinato
ES Gris claro mate satinado
PT Cinza claro mate sedoso
DK Lysegrå silkematt
NO Lysgrå silkematt
SE Ljusgrå sidenmatt
FI Vaaleanharmaa silkkimatta
RU Светло-серый шелковисто-матовый
PL Jasnoszary jedwabiscie matowy
CZ Světla šedá jemně matný
HU Világosszürke, fakóselymes
SK Svetlo sivá hodvábne matný
RO Gri-deschis satinat
BG Светлосиво коприненоматово
SI Svetlo-siva svileni-mat
GR Γκρι ανοιχτό σατινέ
TR Açık gri ipeksi mat

301

K

DE Weiß seidenmatt
GB White silk matt
FR Blanc satiné mat
NL Wit zijdemat
IT Bianco opaco satinato
ES Blanco mate satinado
PT Branco mate sedoso
DK Hvid silkematt
NO Hvit silkematt
SE Vit sidenmatt
FI Valkoinen silkkimatta
RU Белый шелковисто-матовый
PL Biały jedwabiscie matowy
CZ Bílá jemně matný
HU Fehér, fakóselymes
SK Biela hodvábne matný
RO Alb satinat
BG Бяло коприненоматово
SI Bela svileni-mat
GR Άσπρο σατινέ
TR Beyaz ipeksi mat

07

L

DE Schwarz glänzend
 GB Black gloss
 FR Noir brillant
 NL Zwart glanzend
 IT Nero lucido
 ES Negro brillante
 PT Preto brilhante
 DK Sort blank
 NO Sort glansende
 SE Svart blank
 FI Musta kiiltävä
 RU Черный глянец
 PL Czarny błyszczący
 CZ Černá lesklý
 HU Fekete, fényes
 SK Čierna lesklý
 RO Negru-strălucitor
 BG Черно глянцово
 SI Črna sijosa
 GR Μαύρο γυαλιστερό
 TR Siyah parlak

85

M

DE Braun matt
 GB Brown matt
 FR Brun mat
 NL Bruin mat
 IT Marrone opaco
 ES Marrón mate
 PT Castanho mate
 DK Brun mat
 NO Brun matt
 SE Brun matt
 FI Ruskea matta
 RU Коричневый матовый
 PL Brązowy matowy
 CZ Hnědá matný
 HU Barna, fénytelen
 SK Hnedá matný
 RO Maro mat
 BG Кафяво матово
 SI Rjava mat
 GR Καφέ ματ
 TR Kahve mat

75

N

DE Steingrau matt
 GB Stone grey matt
 FR Gris pierre mat
 NL Steengrijs mat
 IT Grigio pietra opaco
 ES Gris piedra mate
 PT Cinza pedra mate
 DK Stengrå mat
 NO Stengrå matt
 SE Stengrå matt
 FI Kivenharmaa matta
 RU Серый камень матовый
 PL Kamiennoszary matowy
 CZ Kamenná šedá matný
 HU Kőszürke, fénytelen
 SK Kamenná sivá matný
 RO Gri stâncos mat
 BG Каменносиво матово
 SI Kameno-siva mat
 GR Γκρι-πλεξ ματ
 TR Taş grisi mat

730

O

DE Orange klar
 GB Orange clear
 FR Orange clair
 NL Oranje helder
 IT Arancio chiaro
 ES Naranja claro
 PT Laranja transparente
 DK Oranje klar
 NO Oransje klar
 SE Oranssi klar
 FI Oranssi kirkas
 RU Оранжевый прозрачный
 PL Pomarańczowy przezroczysty
 CZ Oranžová bezbarvý
 HU Narancs, világos
 SK Oranžová čirý
 RO Oranj curat
 BG Оранжево бистро
 SI Oranžna čista
 GR Πορτοκαλί διάφανο
 TR Turuncu canlı

731

P

DE Rot klar
 GB Red clear
 FR Rouge clair
 NL Rood helder
 IT Rosso chiaro
 ES Rojo claro
 PT Vermelho transparente
 DK Rødbrun klar
 NO Rød klar
 SE Rödbrun klar
 FI Punainen kirkas
 RU Красный прозрачный
 PL Czerwony przezroczysty
 CZ Červená bezbarvý
 HU Piros, világos
 SK Červená čirý
 RO Roșu curat
 BG Червено бистро
 SI Rdeča čista
 GR Κόκκινο διάφανο
 TR Kırmızı canlı

50%

330

Q

382

50%

DE Feuerrot seidenmatt
 GB Fiery red silk matt
 FR Rouge feu satiné mat
 NL Vuurood zijdemat
 IT Rosso fuoco opaco satinato
 ES Rojo fuego mate satinado
 PT Vermelho fogo mate sedoso
 DK Ildrød silkematt
 NO Ildrød silkematt
 SE Eldröd sidenmatt
 FI Tulenpunainen silkkimatta
 RU Огненно-красный шелковисто-матовый
 PL Ognistoczerwony jedwabście matowy
 CZ Ohnivě červená jemně matný
 HU Tűzpiros, fakóselymes
 SK Ohnivá červená hodvábne matný
 RO Roșu aprins satinat
 BG Огненочервено коприненоматово
 SI Ognjeno-rdeča svileni-mat
 GR Κόκκινο φωτιάς σατινέ
 TR Alev kırmızısı ipeksi mat

+

DE Holzbraun seidenmatt
 GB Wood brown silk matt
 FR Brun bois satiné mat
 NL Houtbruin zijdemat
 IT Marrone legno opaco satinato
 ES Marrón madera mate satinado
 PT Castanho madeira mate sedoso
 DK Træbrun silkematt
 NO Trebrun silkematt
 SE Tråbrun sidenmatt
 FI Puunruskea silkkimatta
 RU Древесно-коричневый шелковисто-матовый
 PL Brązowy w odcieniu drewna jedwabście matowy
 CZ Dřevěná hnědá jemně matný
 HU Fa barna, fakóselymes
 SK Drevená hnedá hodvábne matný
 RO Maro lemnos satinat
 BG Дървеснокафяво коприненоматово
 SI Lesno-rjava svileni-mat
 GR Καφέ ανοιχτό σατινέ
 TR Ahşap rengi ipeksi mat

08

R

DE Schwarz matt
 GB Black matt
 FR Noir mat
 NL Zwart mat
 IT Nero opaco
 ES Negro mate
 PT Preto mate
 DK Sort mat
 NO Sort matt
 SE Svart matt
 FI Musta matta
 RU Чёрный матовый
 PL Czarny matowy
 CZ Černá matný
 HU Fekete, fénytelen
 SK Čierna matný
 RO Negro mat
 BG Черно матово
 SI Črna mat
 GR Μαύρο ματ
 TR Siyah mat

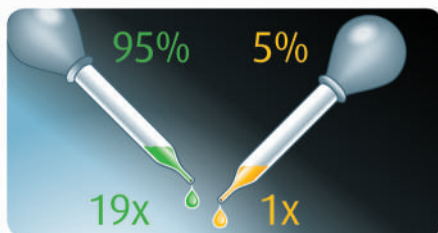

DE Beispiel: mischen
 GB Example: mixing
 FR Exemple: mélanger
 NL Voorbeeld: mengen
 IT Esempio: mescolare
 ES Ejemplo: mezcla
 PT Exemplo: misturar
 DK Eksempel: blanding
 NO Eksempel: blanding
 SE Exempel: blanda
 FI Esimerkki: sekoittaminen

RU Пример: смешивание
 PL Przykład: mieszanie
 CZ Příklad: míchání
 HU Példa: keverés
 SK Příklad: miešanie
 RO Exemplu: amestecare
 BG Пример: смесване
 SI Primer: mešanje
 GR Παράδειγμα: ανάμειξη
 TR Örnek: karıştırma

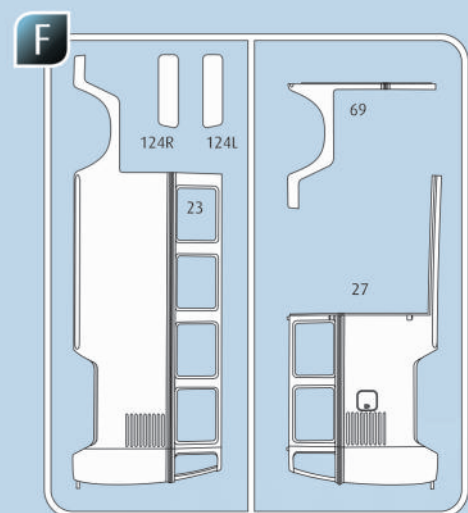
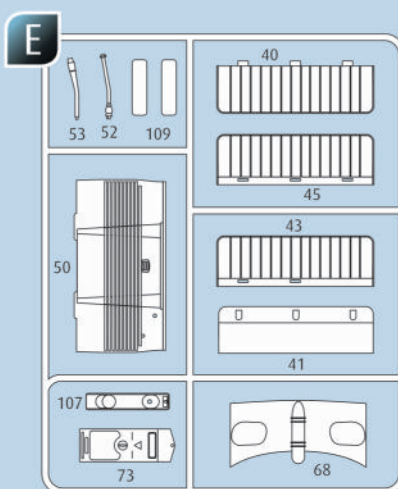
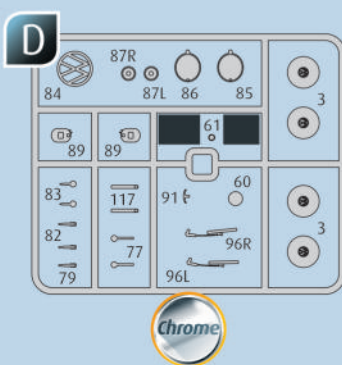
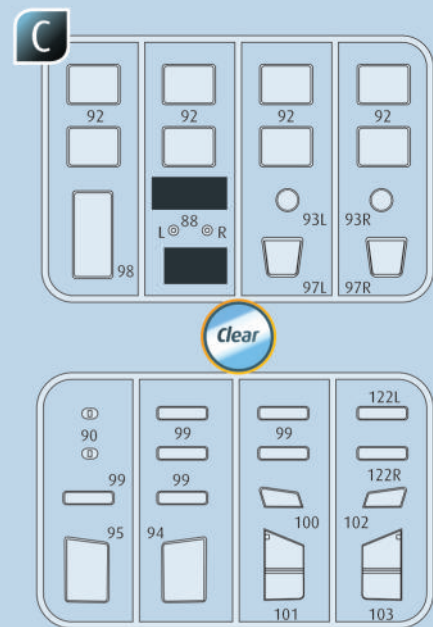
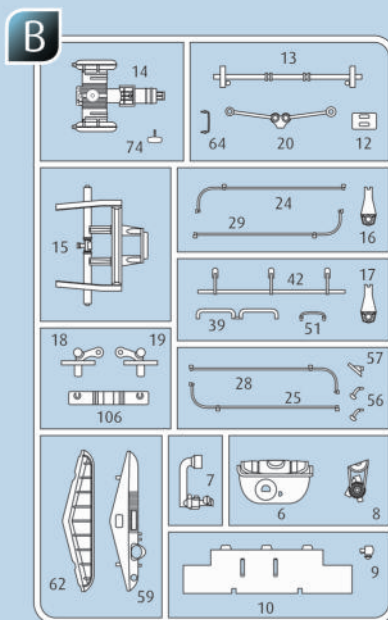
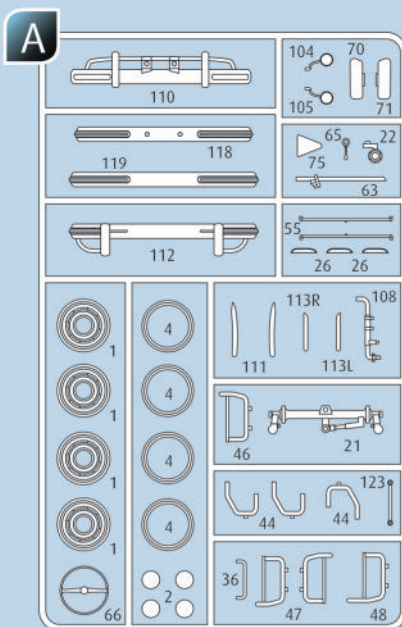

(NE) Nicht benötigte Teile
 (NR) Parts not used.
 (FR) Pièces non utilisées.
 (NL) Niet benodigde onderdelen.
 (IT) Parti non necessarie.
 (ES) Piezas no utilizadas.
 (PT) Peças não utilizadas.

(DE) Dele der ikke skal bruges.
 (NO) Deler som ikke er nødvendige.
 (SE) Ej nödvändiga delar.
 (FI) Tarpeettomat osat.
 (RU) Неиспользуемые детали.
 (PL) Niepotrzebne części.
 (CZ) Nepotřebné díly.

(HU) Szükségtelen alkatrészek.
 (SK) Nepotrebné diely.
 (SI) Piese care nu sunt necesare.
 (BG) Ненужни детали.
 (GR) Μη χρησιμοποιούμενα μέρη.
 (TR) Gerekl olmayan parçalar.

Ersatzteile benötigt?

Kein Problem. Einfach den Revell-Service mit Angabe von Artikel- und Teilenummer kontaktieren. Entweder unter service@revell.de oder Revell GmbH, Abteilung X, Henschelstr. 20-30, 32257 Bünde.*

*Wir bitten um Verständnis, dass eine Gewährleistung nur bei aktuellen Artikeln, die im Zeitraum der letzten 24 Monate erworben wurden, übernommen werden kann. Mit der Ersatzteil-Bestellung können Kosten z.B. für Verpackung und Versand entstehen. Ob diese Kosten anfallen wird im Vorfeld schriftlich durch unseren Service mitgeteilt. Das Angebot kann dann angenommen oder abgelehnt werden. Unfrei eingesandte Ersatzteil-Bestellungen werden von uns nicht angenommen! Dieser Direktservice gilt für die Länder Deutschland, Benelux, Österreich, Frankreich, Großbritannien. Ersatzteil-Bestellungen aus den übrigen Ländern werden über die jeweiligen Distributeure abgewickelt. Bitte kontaktieren Sie Ihren Händler.

Besoin de pièces de rechange ?

Il vous suffit de contacter le service Revell et d'indiquer la référence de l'article et de la pièce. Soit en écrivant par mail à service@revell.de (uniquement pour la France) ou par courrier à Revell GmbH, Département X, Henschelstr. 20-30, D-32257 Bünde.*

*La garantie s'applique pour les articles présents au catalogue et achetés au cours des 24 derniers mois. Merci de votre compréhension. La commande de pièces de rechange peut donner lieu à des frais supplémentaires, par ex. pour l'emballage et le port. Notre service client vous en informera au préalable par écrit. Vous pourrez accepter ou refuser le devis. Nous n'acceptons pas les commandes de pièces de rechange envoyées sans affranchissement ! Ce service direct est valable pour les pays suivants : Allemagne, Benelux, Autriche, France, Grande-Bretagne. Les commandes de pièces en provenance d'autres pays sont traitées par les distributeurs correspondants. Veuillez contacter votre revendeur.

Need spare parts?

No problem. Contact Revell Service with the item number and part numbers you need: service@revell.de or Revell GmbH, Unit 10, Old Airfield Industrial Estate, Cheddington Lane, Tring, Herts, HP23 4QR, Great Britain.*

*We request your understanding that a warranty can only be accepted for current articles which have been purchased in the last 24 months. Orders for spare parts may also be subject to costs for packaging and shipping. You will be notified in advance by our Service department if such costs are incurred. The offer can then be accepted or rejected. We will not be able to process any postal requests unless correct postage has been applied to mailing! This direct service applies to the countries: Germany, Benelux, Austria, France, and the United Kingdom. Spare part orders from other countries are processed by the local distributors. Please contact your dealer.

Hebt u reserveonderdelen nodig?

Geen probleem! Neem eenvoudig contact op met de klantenservice van Revell en geef ons het artikel- en onderdeelnummer door. U kunt ons bereiken op service@revell.de of per post: Revell GmbH, Afdeling X, Henschelstr. 20-30, 32257 Bünde.*

*Wij vragen uw begrip voor de omstandigheid, dat er alleen garantie kan worden geboden voor actuele artikelen, die in de afgelopen 24 maanden zijn gekocht. Met het bestellen van reserveonderdelen kunnen kosten gemoeid zijn, bijv. voor verpakking en verzending. U wordt vooraf schriftelijk door onze klantenservice op de hoogte gesteld als er kosten zouden ontstaan. Het aanbod kan dan worden aangenomen of afgewezen. Wij nemen geen ongefrankeerde bestellingen van reserveonderdelen aan! Deze rechtstreekse service wordt verleend in de landen Duitsland, de Benelux, Oostenrijk, Frankrijk en Groot-Brittannië. Bestellingen van reserveonderdelen in de overige landen worden afgewikkeld via de betreffende distributeurs. Neem hiervoor contact op met uw verkoper.

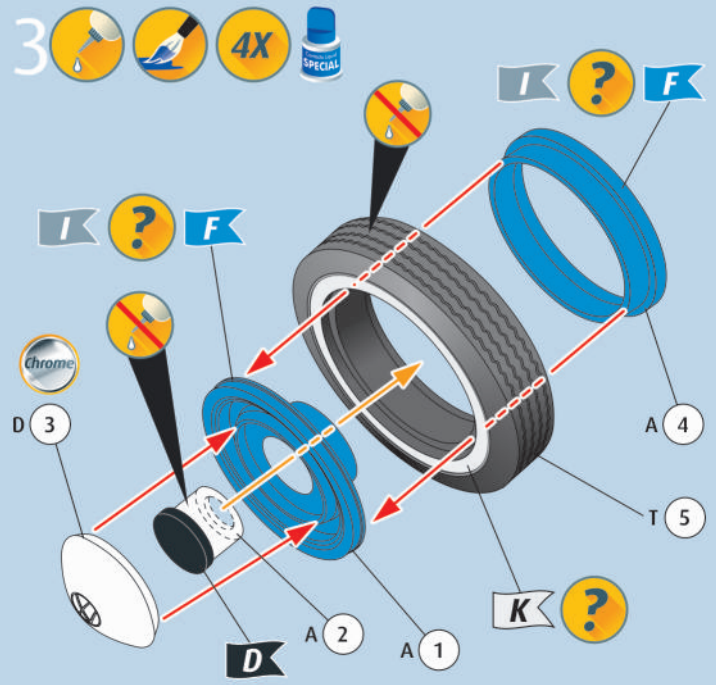
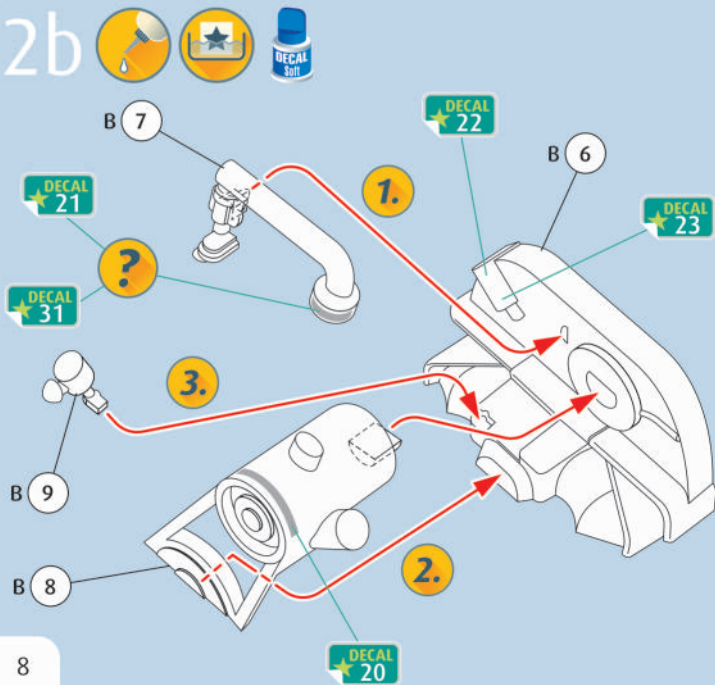
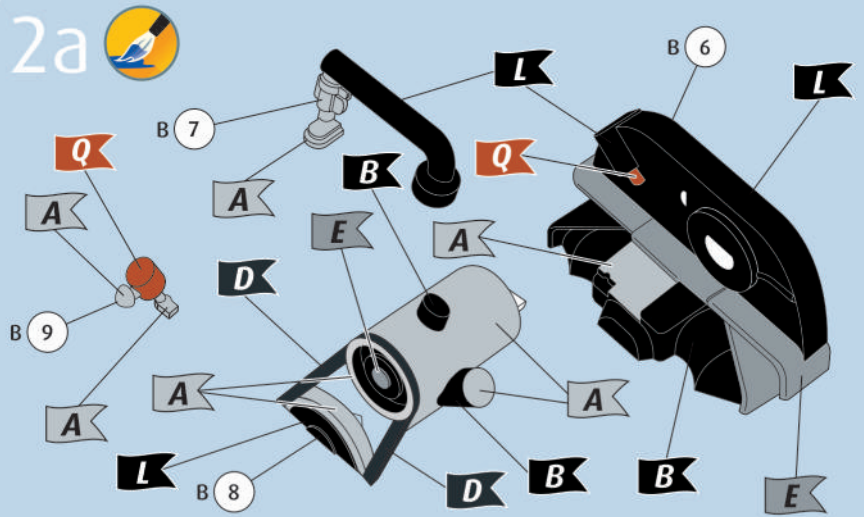
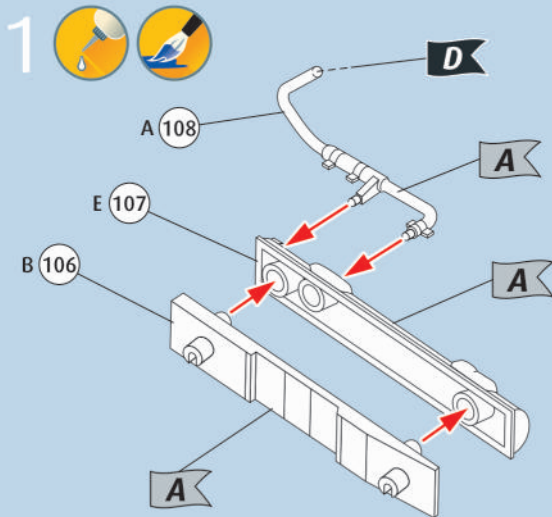
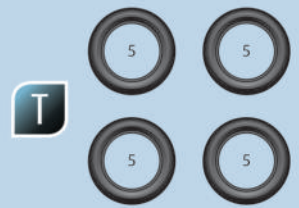
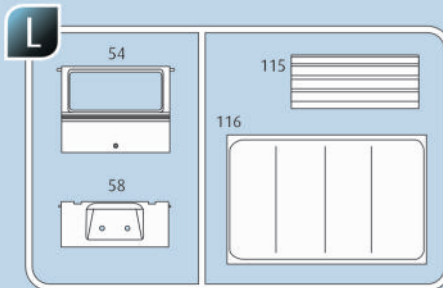
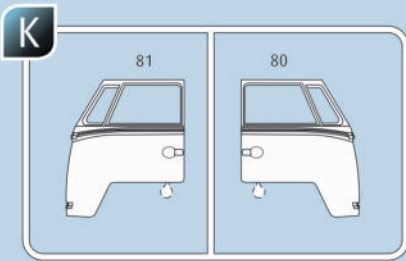
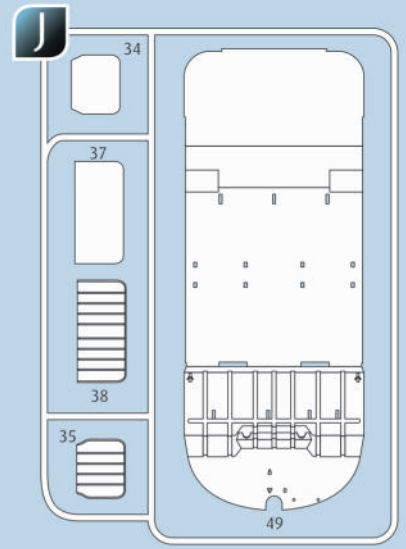
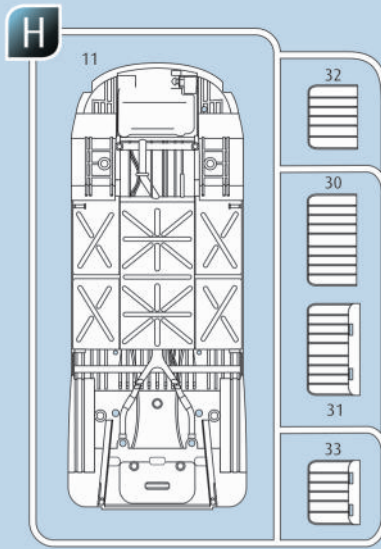
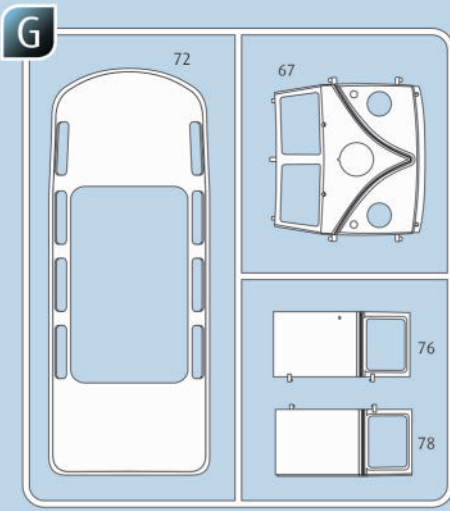

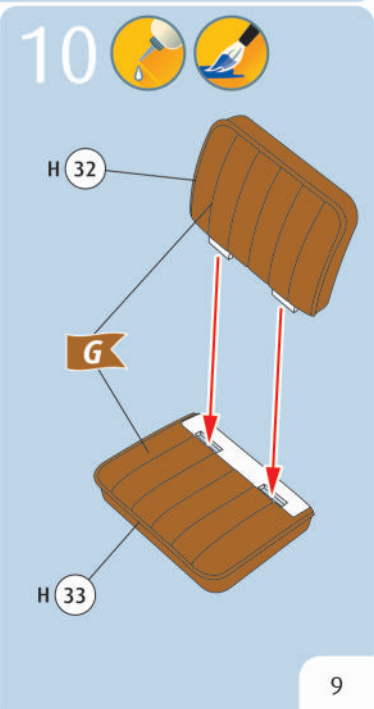
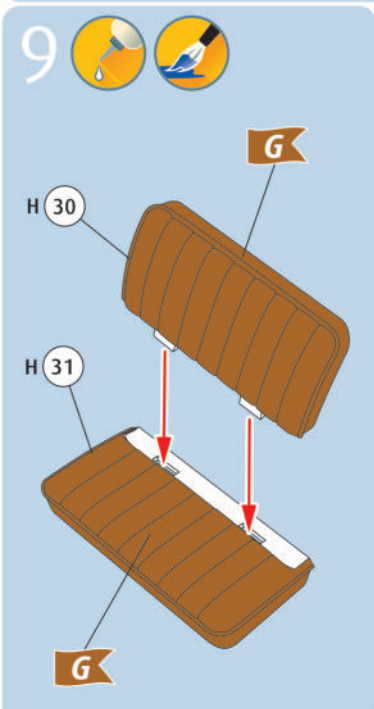
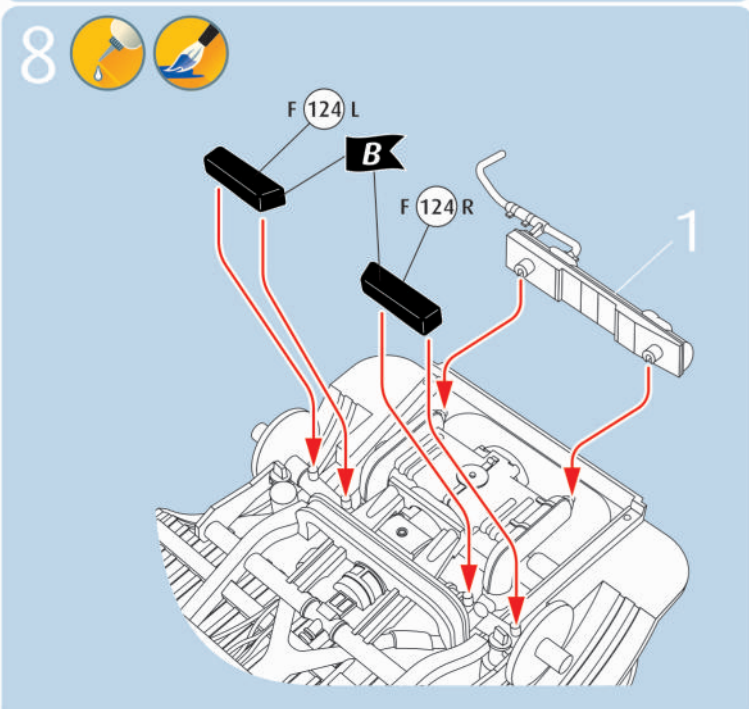
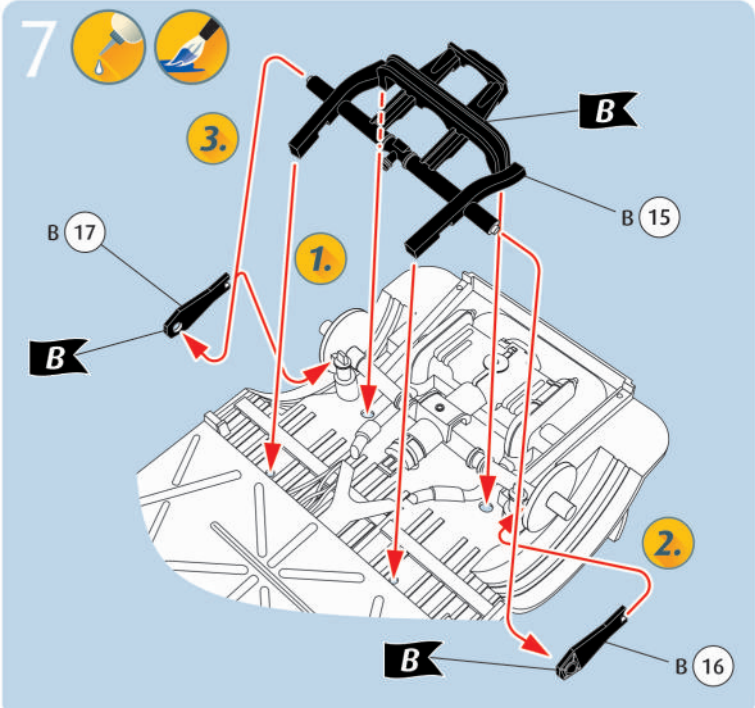
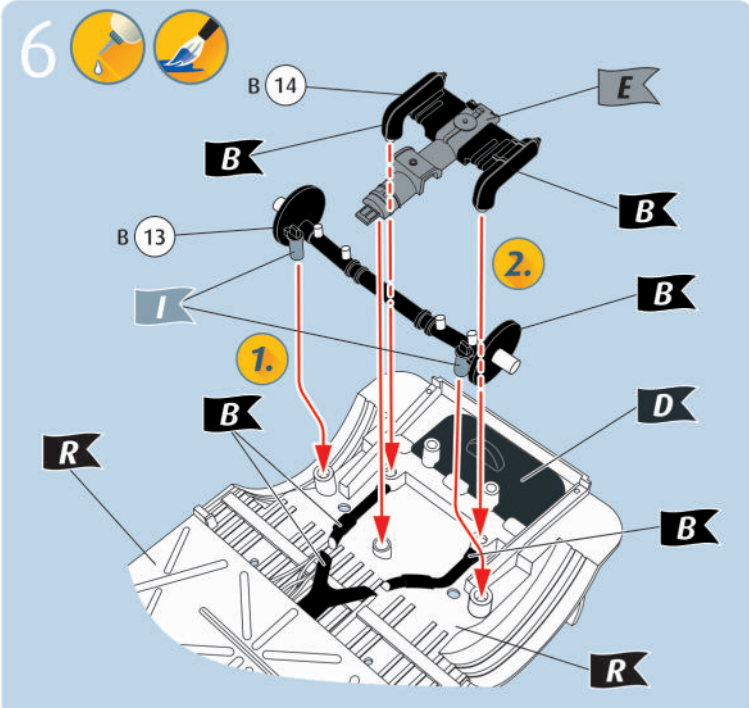
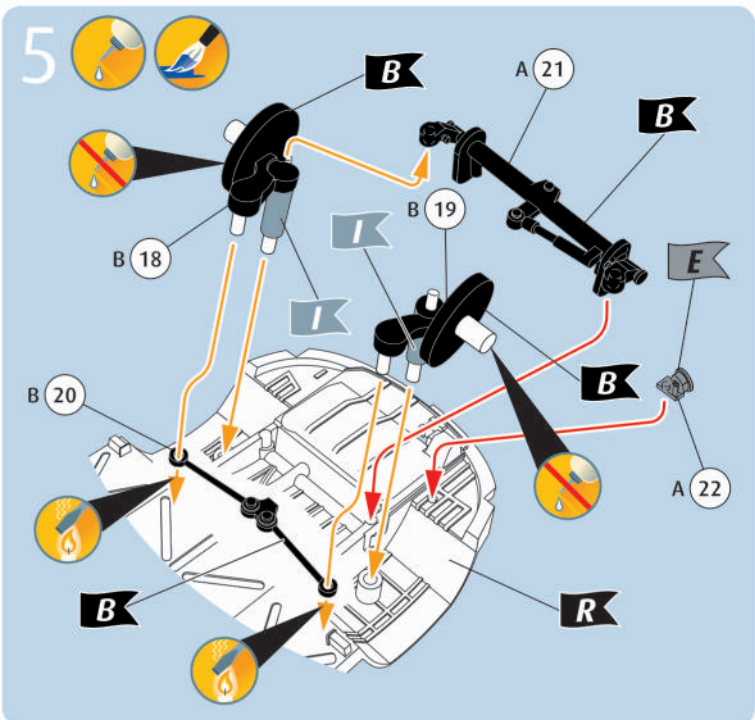
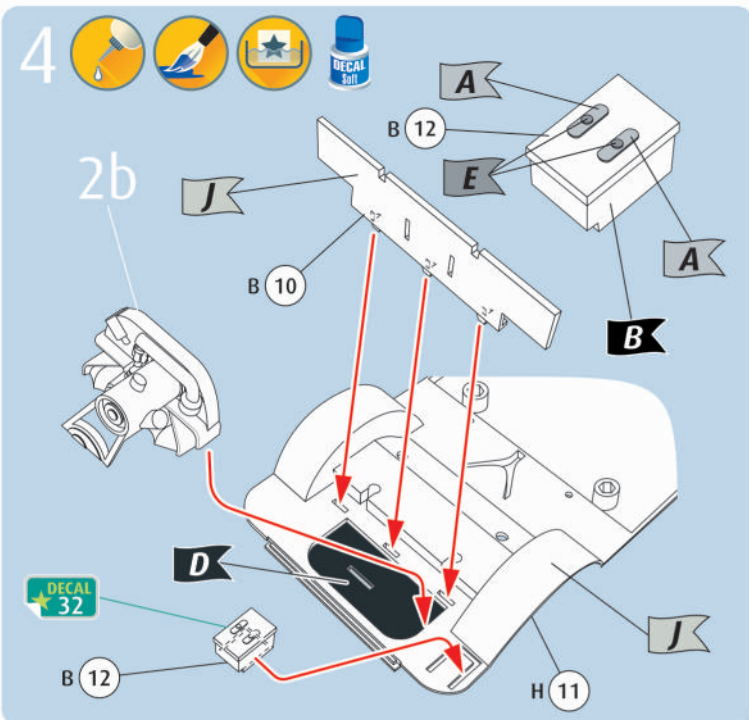

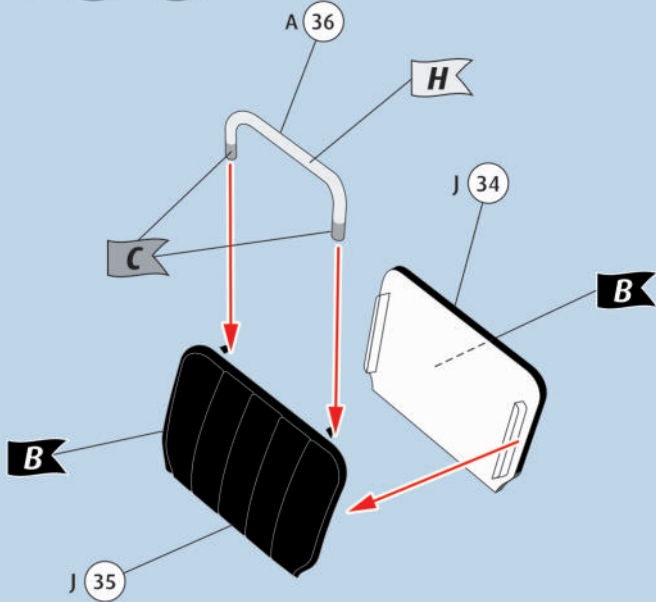
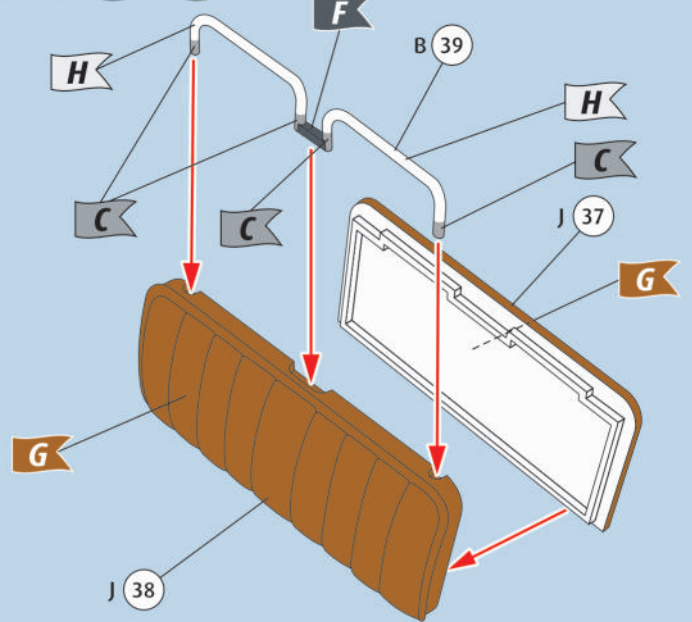
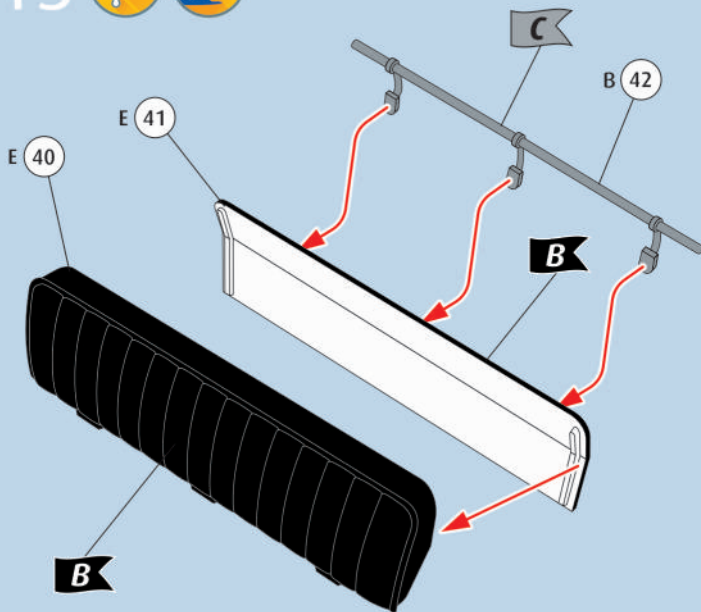
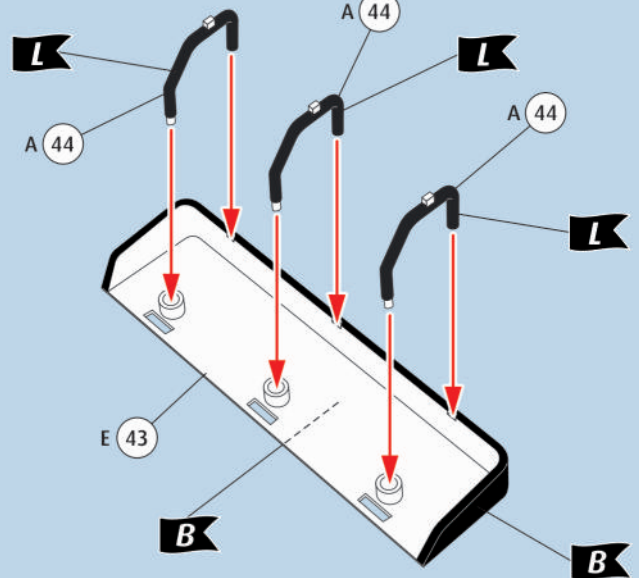
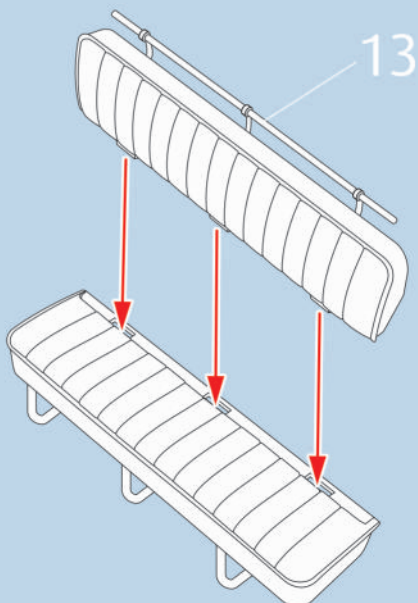
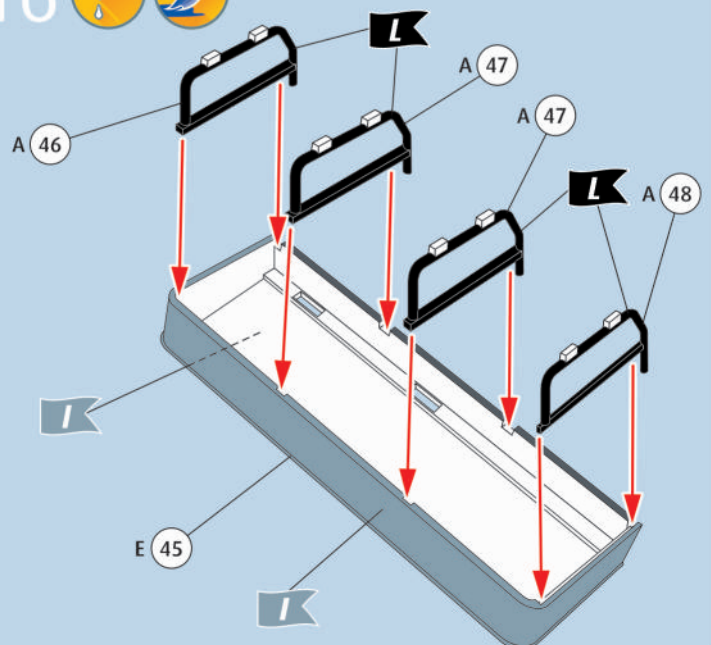
11  12  13  14  15 16  

17

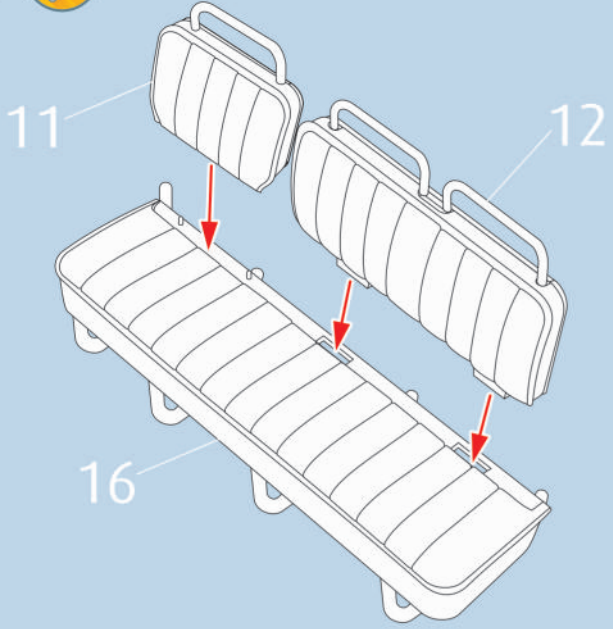

18

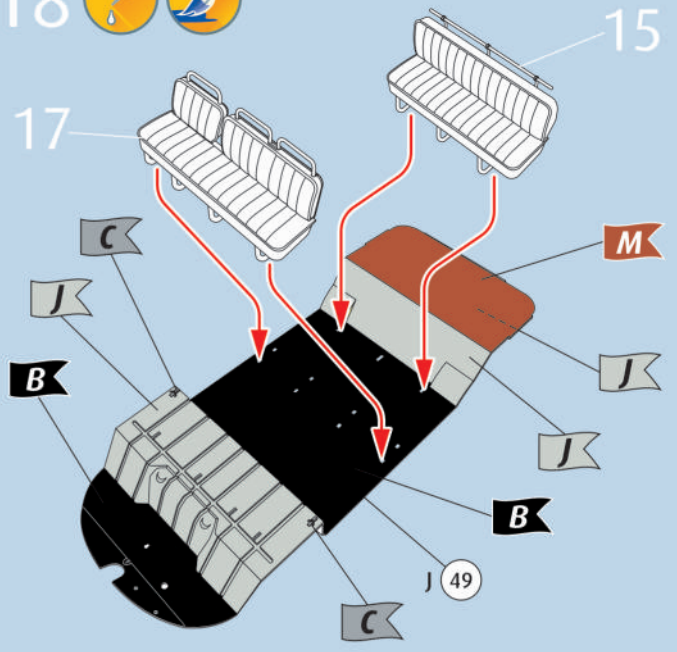

19

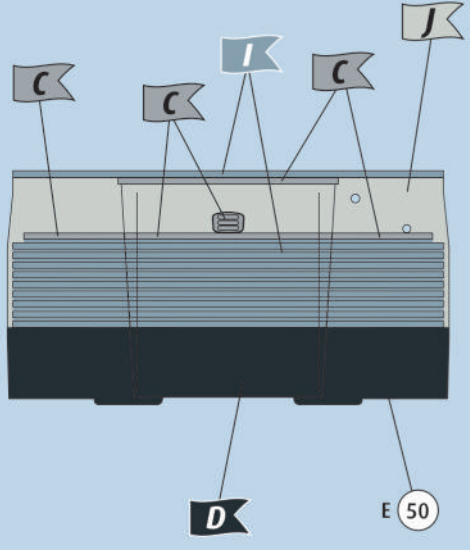

20

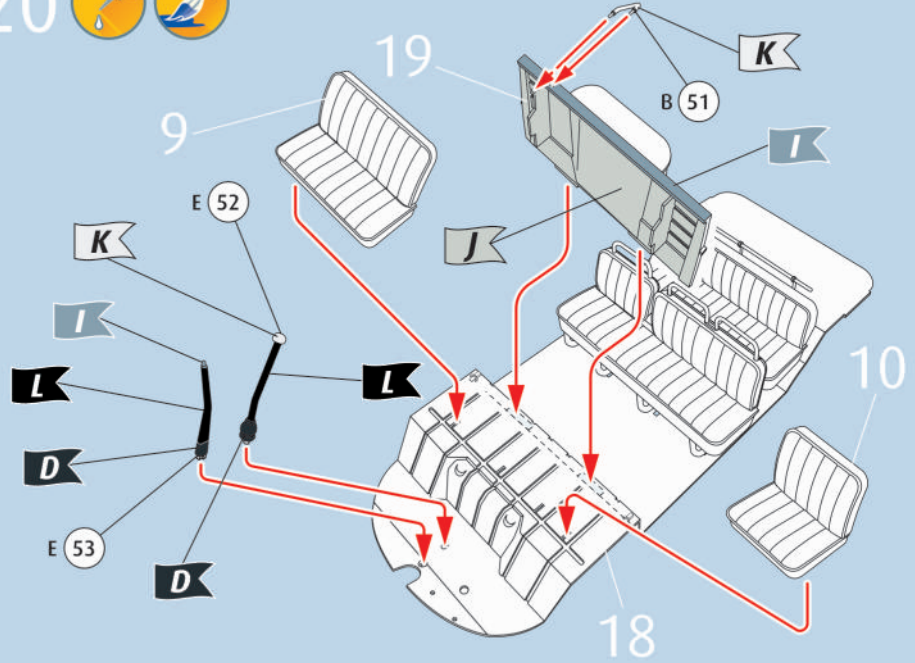

21

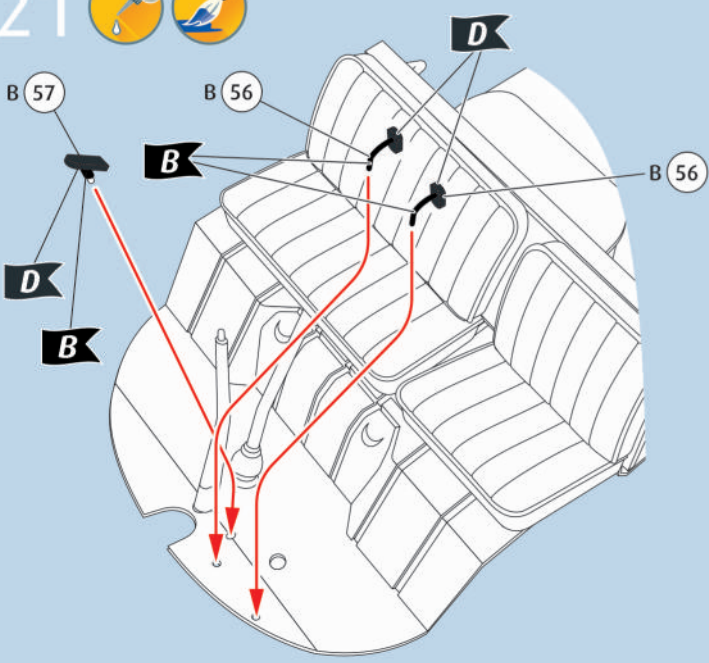

22

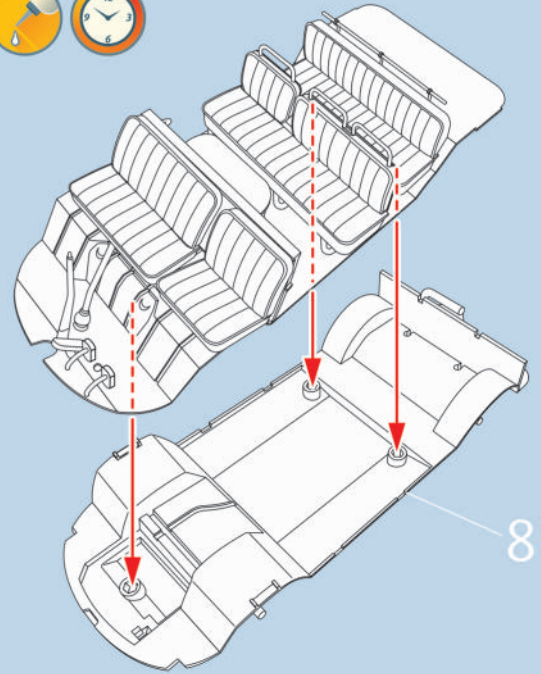

23

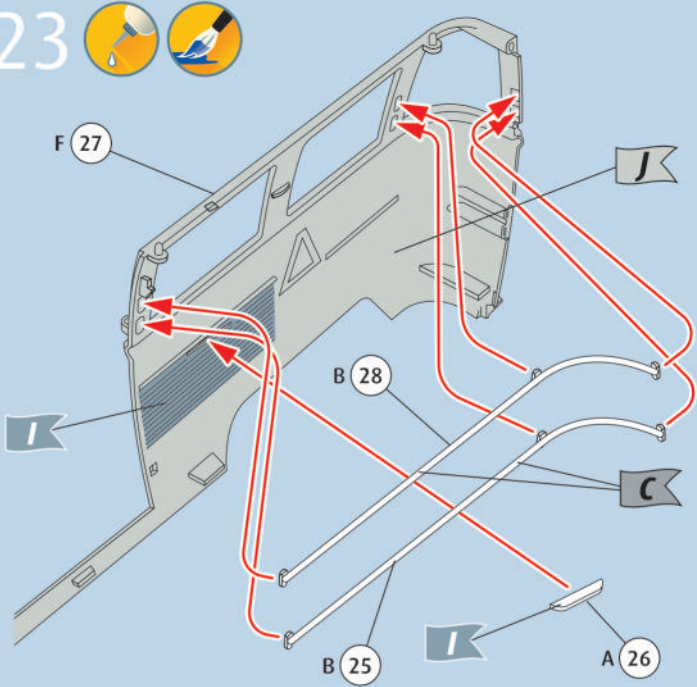

24

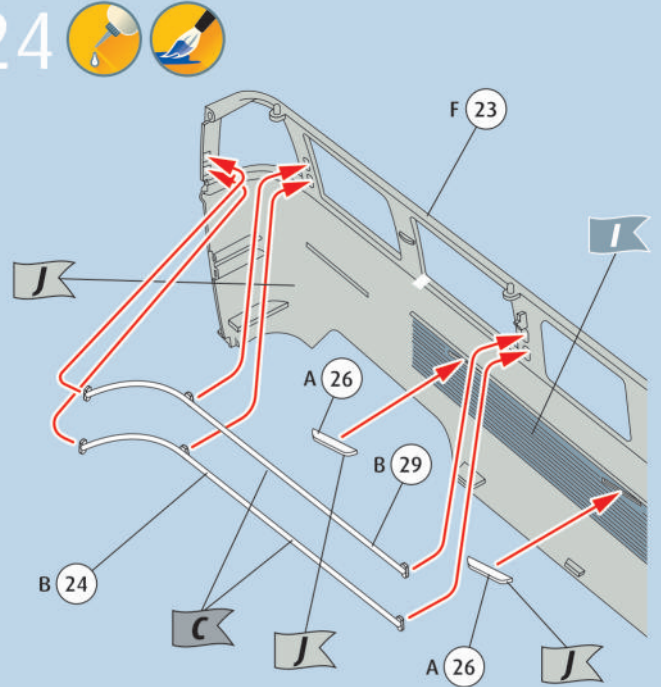

25

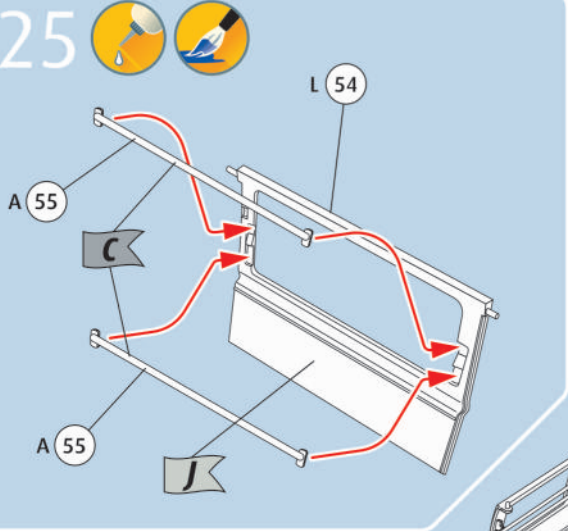

26

56

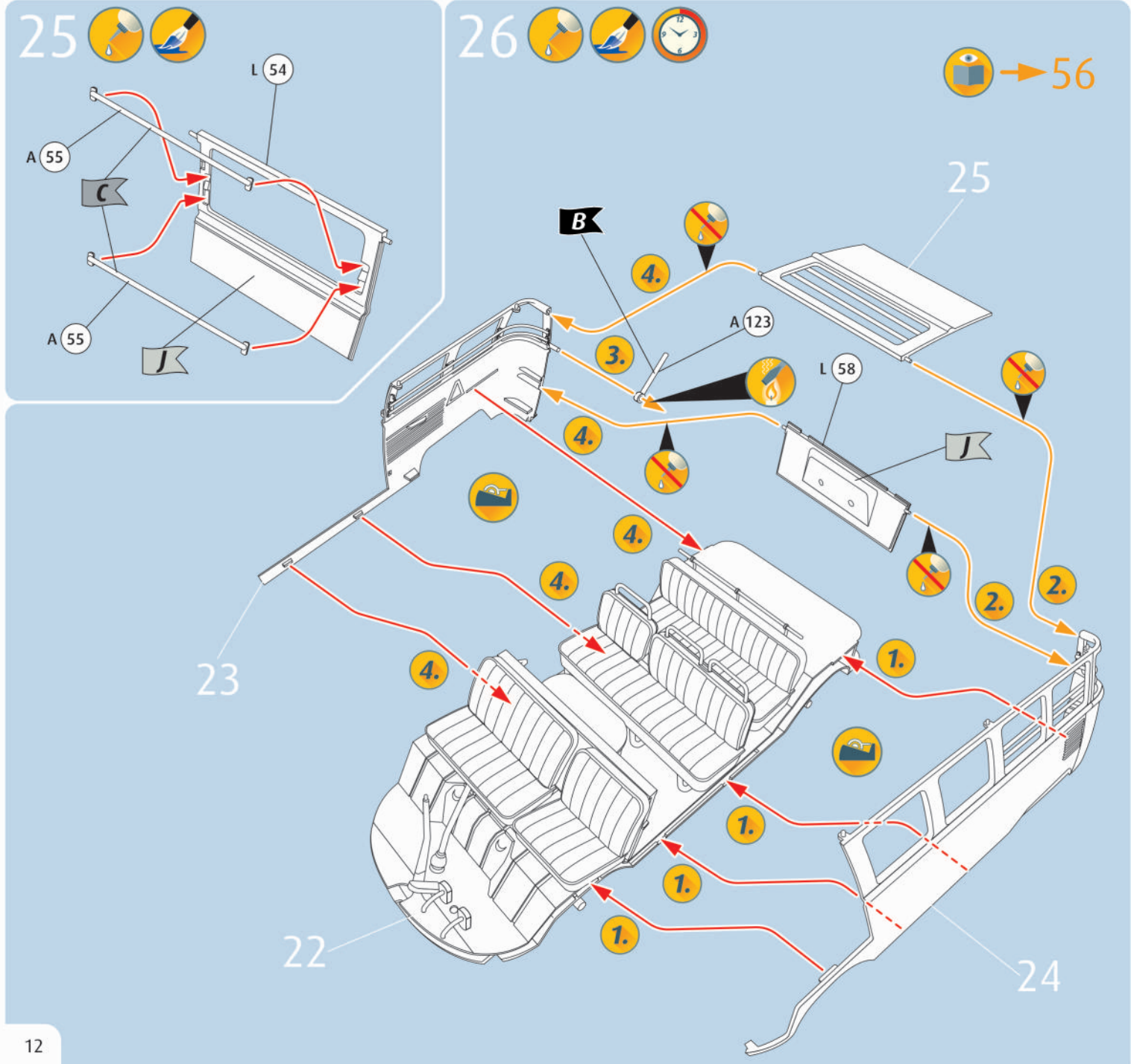

27

Assembly diagram 27 showing the application of chrome and decals to a boat's hull. Components include D 61, D 60, B 64, B 59, C, H, K, J, and decals 33, 34, 27, 35. Chrome caps are also shown.

28

Assembly diagram 28 showing the installation of the steering wheel and throttle. Components include A 66, A 65, A 63, C, K, L, and decal 16.

29

Assembly diagram 29 showing the installation of the outboard motor. Components include B 62 and K.

30

Assembly diagram 30 showing the installation of the motor bracket. Components include G 67, H, J, E 68, N, and a clock icon.

31

Assembly diagram 31 showing the installation of the motor and seat. Components include F 69, H, J, A 70, A 71, and a clock icon. Includes a reference to 41/56 and a question mark icon.

32

Assembly diagram 32 showing the application of chrome to the door handle. Components include J, D 77, G 76, and a chrome cap.

33

Assembly diagram 33 showing the application of chrome to the door trim. Components include J, D 77, I, G 78, and a chrome cap.

34

Assembly diagram 34 showing the installation of the door. Components include 31, 32, 33, D 79, and a warning icon.

35     → 56

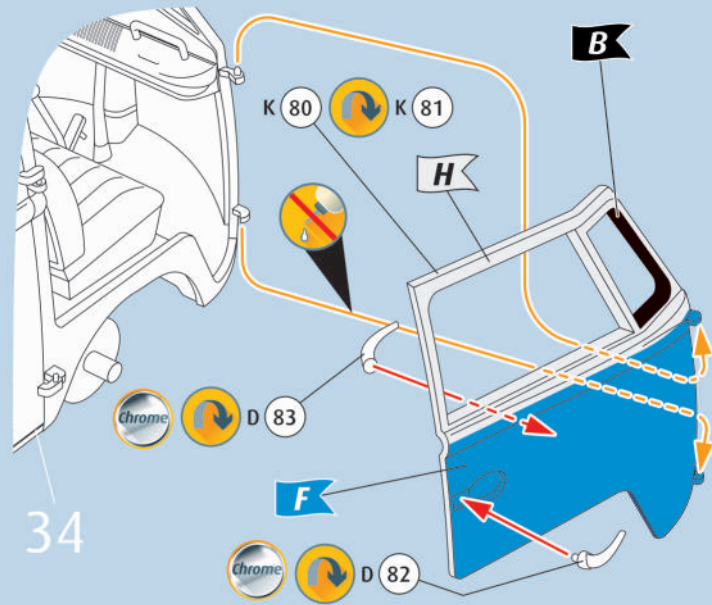

36     

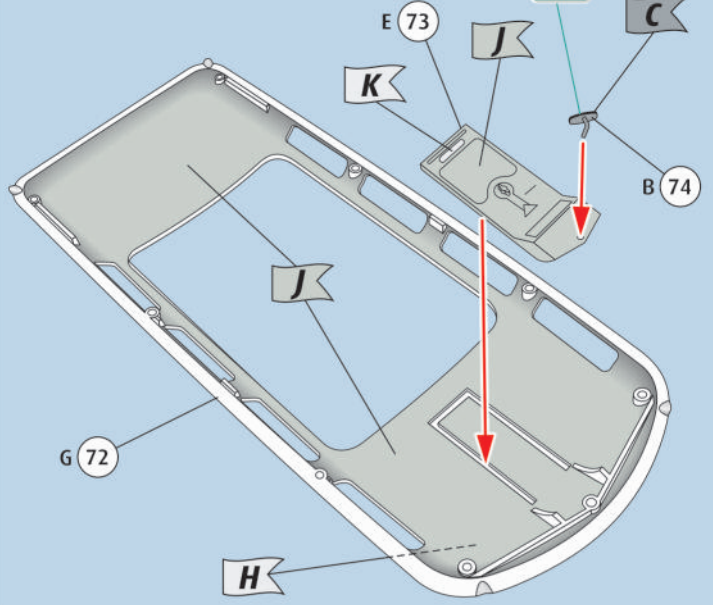

37  

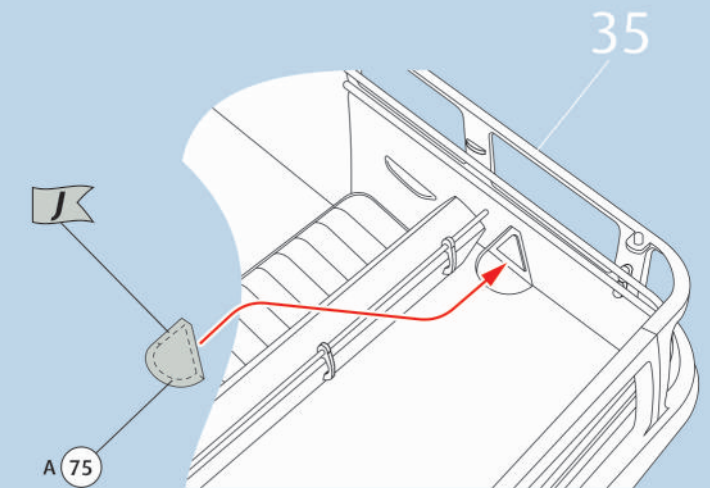

38  

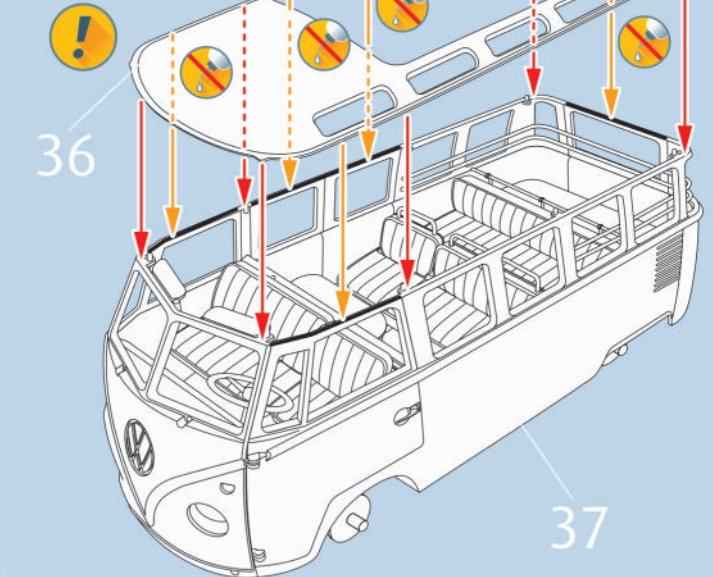

39  

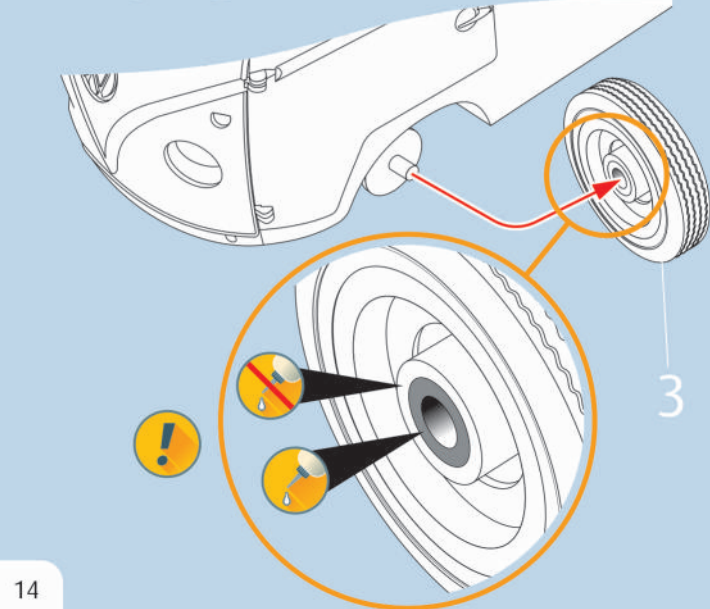

40  

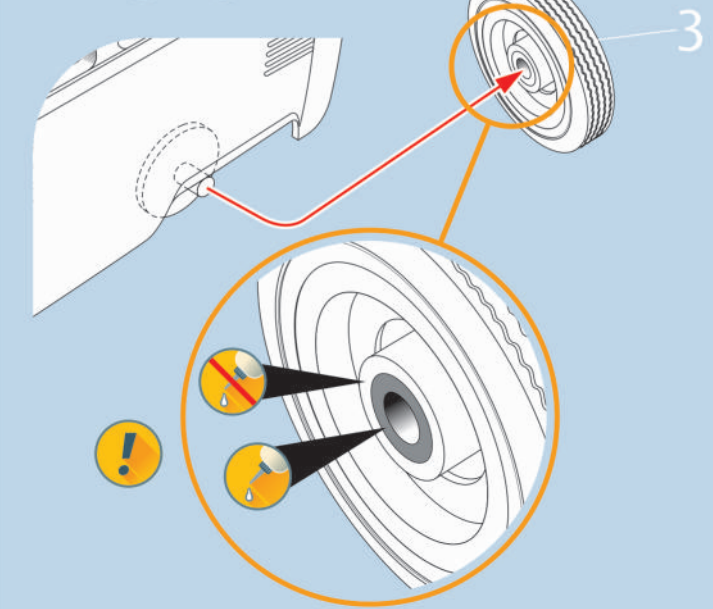

41

DECAL 81
DECAL 73
DECAL 72
1.
2.
3.
D 84
D 86
D 85
C 93 L
C 93 R
31

42

L 115
L 116
D 117
N
J
Chrome

43

B
C 122 L
C 122 R
C 99
Clear

2.
1.

44

C 92
B
Clear

1.
2.

45

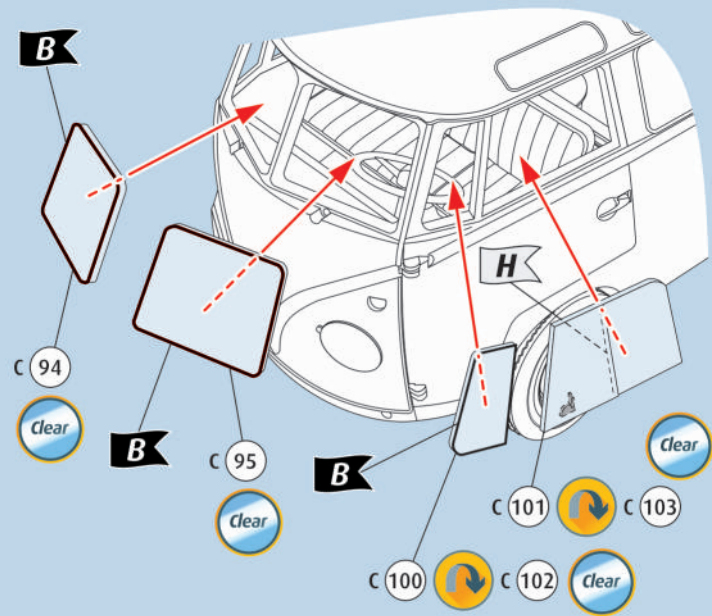

46

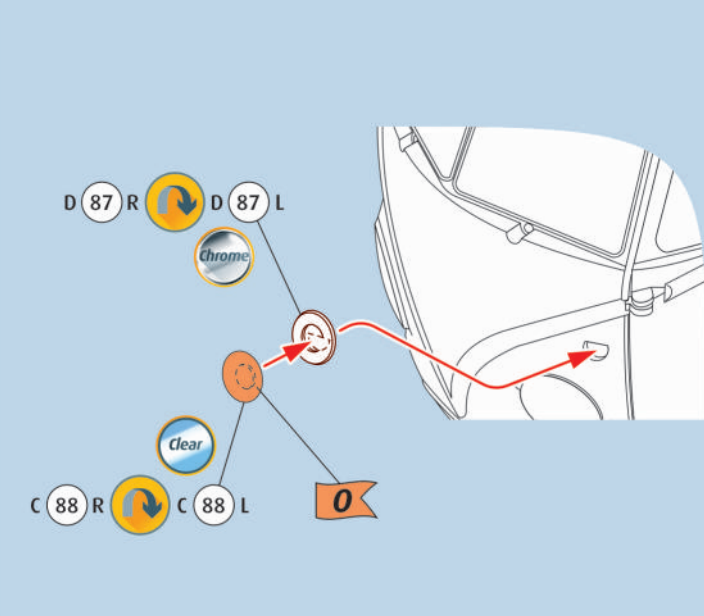

47

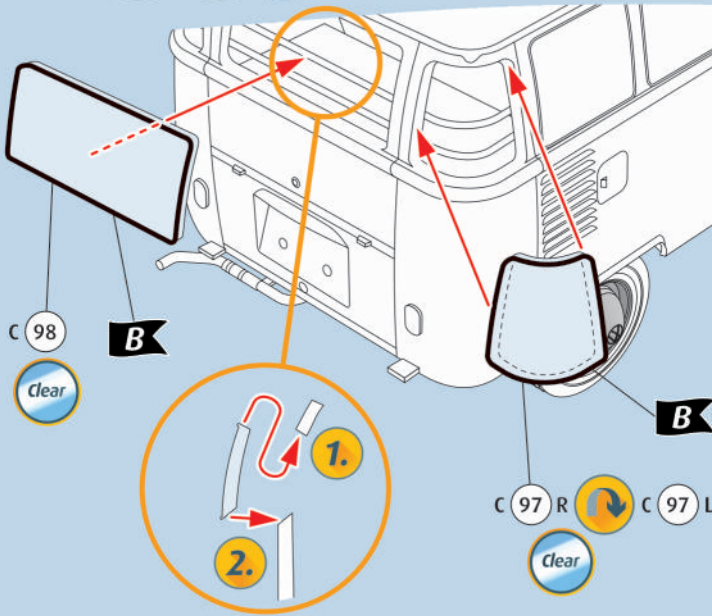

48

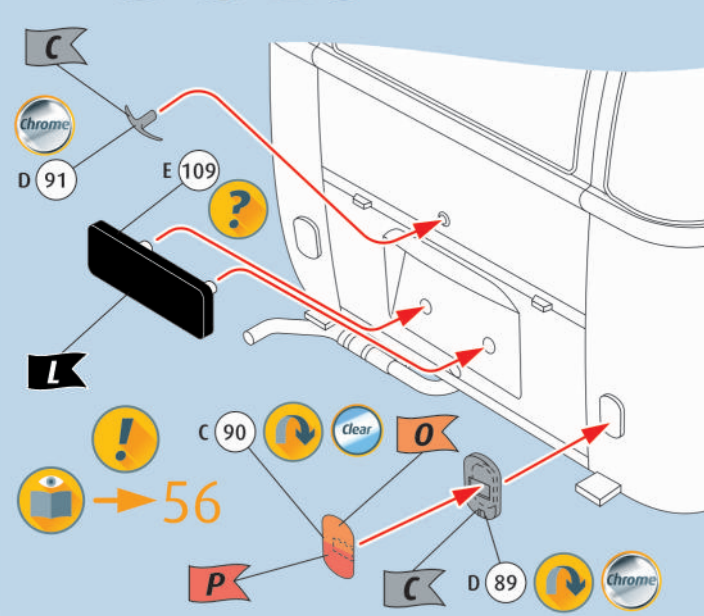

49

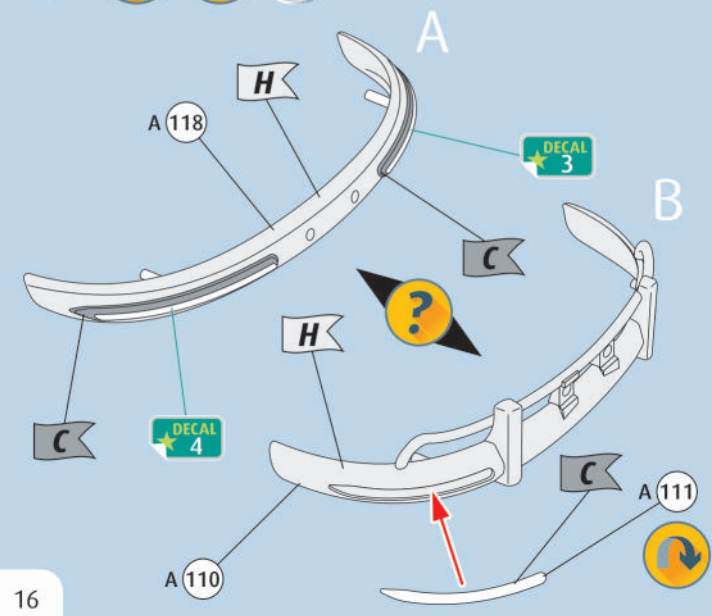

50

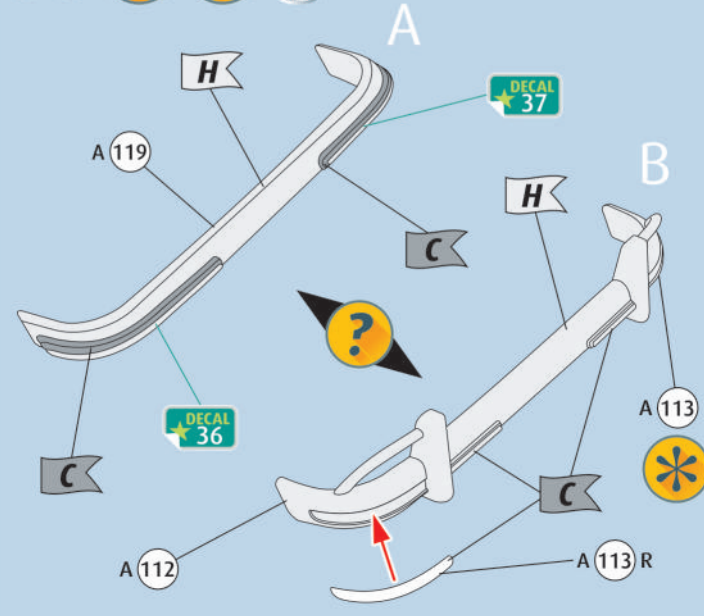

51



56

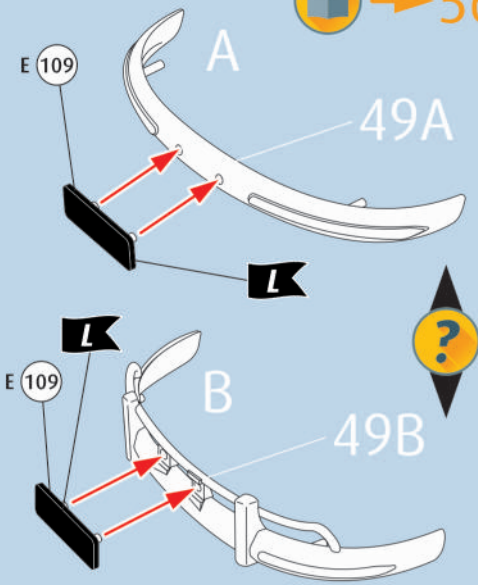

52

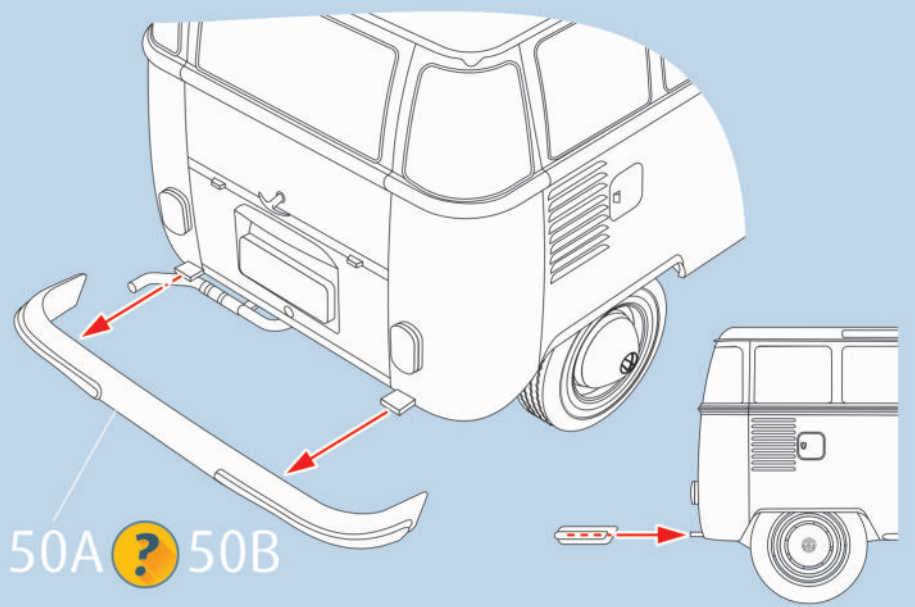

53



51B
51A

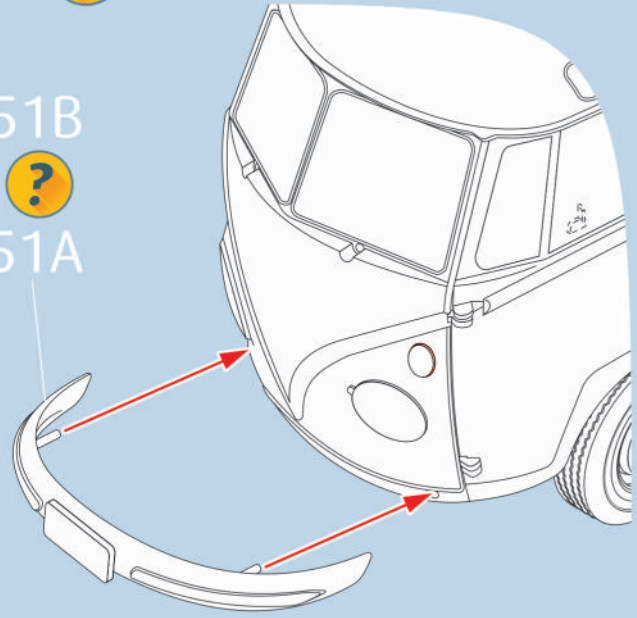

54

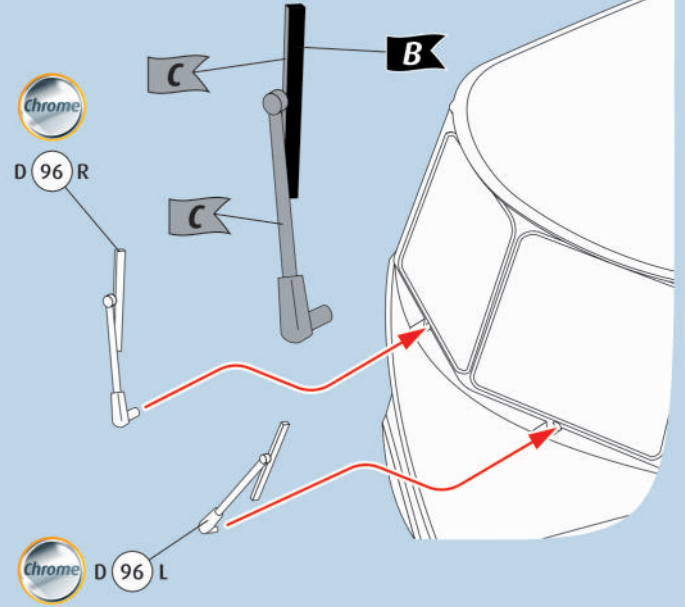

55

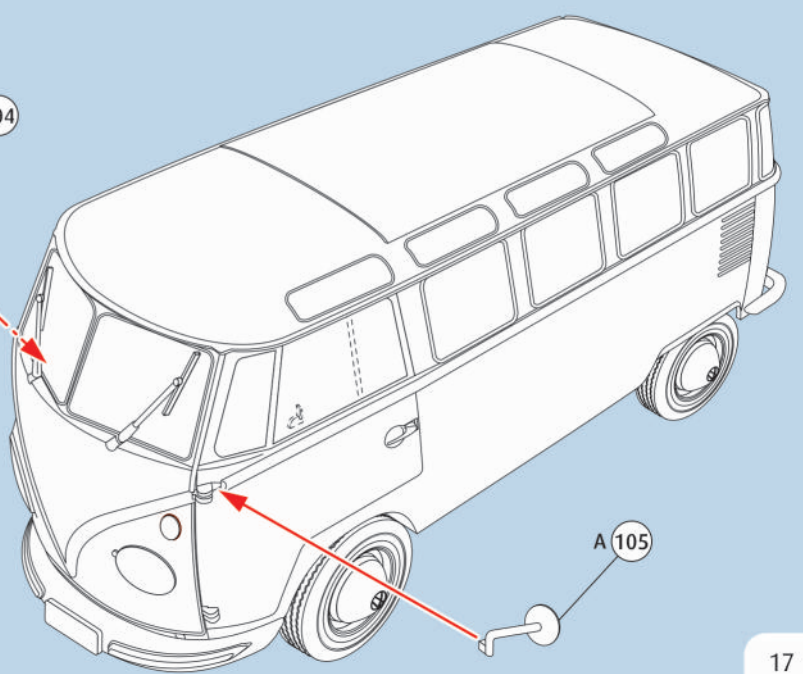
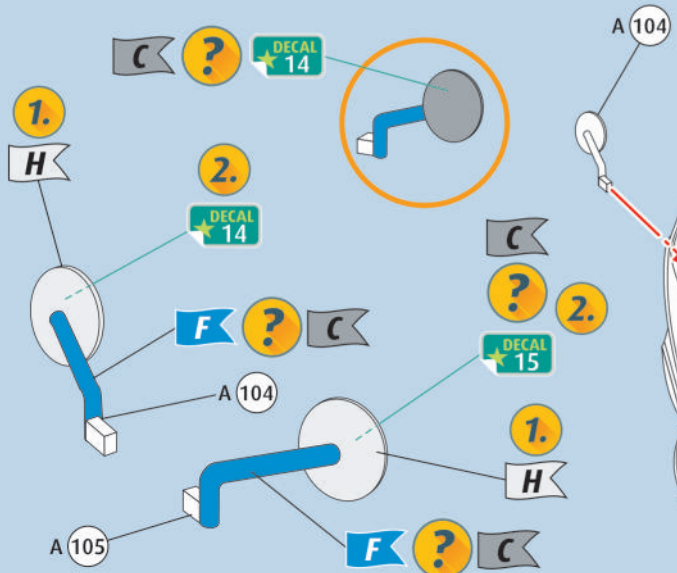

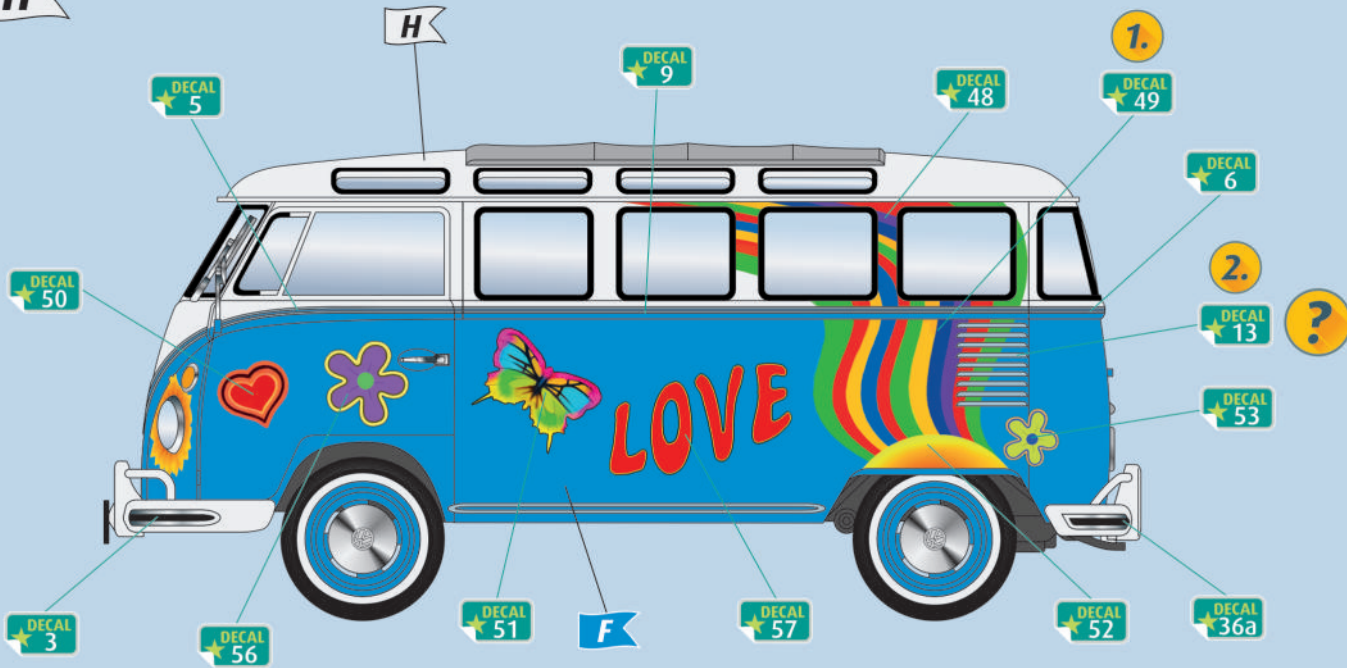

56a

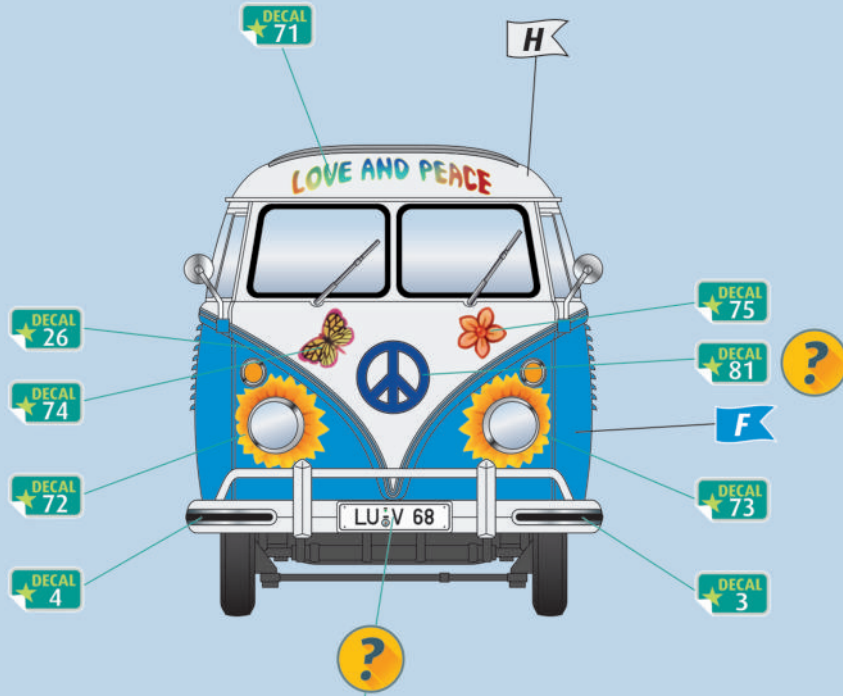

DECAL 17	NL	DECAL 38	DECAL 45
F	DECAL 24	GB	DECAL 40
USA	DECAL 29	D	DECAL 43

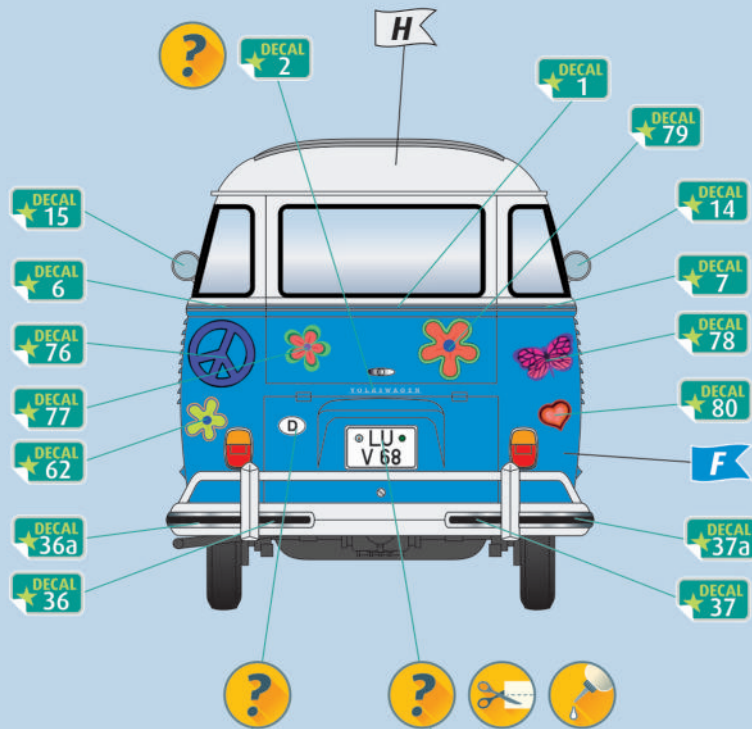

D	DECAL 19	NL	DECAL 39
F	DECAL 25	GB	DECAL 41
USA	DECAL 30		

DECAL 18	NL	DECAL 38	DECAL 45
F	DECAL 24	GB	DECAL 42
USA	DECAL 29	D	DECAL 44

